

# Andreu World

Contemporary Design  
Manufacturing Culture

Catalog

# **Andreu World**

Contemporary  
Design  
Manufacturing  
Culture

Catalog



Design and quality of life make up the essence of our creations. In this new catalog we present a wide range of seating and tables, based in freedom of imagination. We are not bound to general industry formalities, affording us endless selections of materials, technologies, finishes and colors which make for seating and table solutions expressing our deep culture of quality, respect for design and our constant search for harmony, comfort and innovation. These values are accompanied by a constant commitment to the environment and to minimizing environmental impact in the production of all our collections. To do so, Andreu World works with 100% sustainable wood obtained from replenished forests that are certified by the Forest Stewardship Council (FSC®). The FSC guarantees the chain of custody, from the origin of the raw material to the finished product. Since its inception Andreu World has been faithful to its mission: manufacture products with carefully chosen materials that convey quality of life; design elegant pieces from their conception; establish a discreet dialogue in all types of spaces, in all types of rooms and in the diverse locations around in the world. This versatility allows us to work closely with architects, designers, and creators from many different cultures, all of whom see in Andreu World a reality capable of resolving and providing high quality responses in all types of projects and environments, from public spaces to the favorite corner of our home. In short, this catalog to a certain degree summarizes our best selection of products, bringing together the creativity and effort of great designers, our team and, of course, our customers, who make Andreu World a distinguished brand and international reference in the furniture sector.







Diseño y calidad de vida forman parte de la esencia de todas nuestras creaciones. En este nuevo catálogo te presentamos una amplia gama de asientos y mesas que expresan una profunda cultura de calidad, diseño y una búsqueda constante de armonía, bienestar e innovación, basados en una extensa libertad de propuestas formales, materiales, tecnología, acabados y colores. A estos valores, se suma el compromiso constante con el respeto al medio ambiente y la minimización del impacto ambiental en la producción de todas nuestras colecciones. Por ello, Andreu World, trabaja con el 100% de la madera sostenible, procedente de bosques reforestados que cuentan con la certificación FSC® (Forest Stewardship Council) y garantizan el cumplimiento de la cadena de custodia, desde su origen hasta el producto final.

Desde su creación, Andreu World es fiel a una constante: fabricar piezas con materiales muy cuidados que transmitan calidad de vida. Piezas elegantes que desde su concepción establecen un diálogo discreto en todo tipo de espacios, en cualquier tipo de ambiente y en los lugares más dispares del mundo. Esta versatilidad nos permite trabajar estrechamente con arquitectos, diseñadores, interioristas y creadores de muy diversas culturas, que ven en Andreu World una realidad capaz de solucionar y dar respuestas de la máxima calidad en todo tipo de proyectos y entornos, desde el espacio público al rincón preferido de nuestro hogar.

En definitiva, este catálogo sintetiza algo más que nuestra mejor selección de productos, ya que reúne la creatividad y el esfuerzo conjunto de grandes diseñadores, de nuestro equipo humano y, por supuesto, de nuestros clientes que hacen de Andreu World una marca diferenciada y un referente internacional en el universo del hábitat.



If the world is moving at an unstoppable pace, we will continue to seek new ways to respond and adapt to these changes and, if possible, try to be able to anticipate what may arise.

The catalog contains a new series of designs that adapt to new behaviors, needs and desires; products that evolve and amend certain things to remain the same. Andreu World has made a constant search for new proposals, researching the quality and strength of materials, innovation and sustainability, as well as the excellence of its implementation and the warmth of their results, which is an ideology itself.

In this sense, Andreu World continues on the path that was started six decades ago which is to improve its products and the variety of its uses in all kinds of applications and in any architectural space. Appropriate to the times, our product advances to corporate solutions in both seating and tables that broadens perspectives with additions to the scope of the sofas, making comfort an intrinsic quality of all our designs.

Si el mundo avanza de manera imparable, y esa es su razón de ser, nosotros vamos a seguir buscando nuevos modos de respuesta y adecuación ante esos cambios y, a ser posible, tratar de ser capaces de anticiparlos.

El catálogo de novedades que aquí comienza contiene una serie de diseños que se adaptan a nuevos comportamientos, necesidades y deseos; productos que avanzan y modifican algunas cosas para seguir siendo los mismos. Andreu World ha hecho de la búsqueda constante de nuevas propuestas, de la calidad y resistencia de los materiales, de la innovación y la sostenibilidad, así como de la excelencia de su puesta en práctica y la calidez de sus resultados, un ideario propio.

En este sentido, Andreu World sigue en el camino iniciado seis décadas atrás, mejorando sus productos y la polivalencia de sus usos en todo tipo de ambientes y cualquier espacio arquitectónico. Adecuado a los tiempos, nuestro catálogo de productos avanza hacia las soluciones corporativas tanto en asientos como en mesas y amplía perspectivas con incorporaciones en al ámbito de los sofás, haciendo del confort una cualidad intrínseca de todos nuestros diseños.

Andreu World offers more references and versions other than what is shown in this catalog. For more information, consult the commercial department or visit our website at: [www.andreuworld.com](http://www.andreuworld.com)

Andreu World dispone en su oferta de más referencias y versiones de las que se muestran en este catálogo. Para más información, consultar con el departamento comercial o visitar nuestra web: [www.andreuworld.com](http://www.andreuworld.com)



## Guarantee Garantía

\*5

5-year guarantee on our products against material and manufacturing defects.

5 años de garantía en nuestros productos contra todos los defectos en materiales y procesos de elaboración.

## Quality and environmental Policy Política de calidad y medioambiente

Andreu World has implemented environmental management systems in our manufacturing processes and we operate in accordance with all major international standards and certifications of compliance and environmental care for our products. These standards and certifications are the ultimate guarantee of the sustainable, durable and quality chairs and tables that we produce. In this context, the implementation of 14006 Ecodesign certification and the UNE EN ISO 9001 and 14001 standard to our collections has allowed us to rethink our furniture solutions in order to optimize energy consumption during manufacturing and to improve the processes of finishing, painting, packaging and logistics.

Andreu World ha implementado sistemas de gestión medioambiental en sus centros de producción, y cumple con las principales normas y certificaciones internacionales de respeto y cuidado ambiental para sus productos. Esta es la máxima garantía que nos permite ofrecer sillas y mesas de calidad, sostenibles y duraderas procedentes de un proceso de fabricación respetuoso en todo el ciclo de vida del producto. En este contexto, la aplicación de la certificación Ecodiseño ISO 14006 y las normativas ISO 9001 e ISO 14001 sobre nuestras colecciones permite ofrecer soluciones de mobiliario pensadas para optimizar su consumo energético en la fase de fabricación y conseguir una mejora en otros procesos de acabados, pintura, embalaje o logística.



## Design protection Protección del Diseño



All Andreu World designs are protected by industrial design registries, design patents, copyrights, and other intellectual property rights worldwide.

Todos los diseños de Andreu están protegidos por registros de diseño industrial, design patent, copyright y derechos de propiedad intelectual en todo el mundo

## Design Award Premios de Diseño



Andreu World has been internationally recognized with the Red Dot Design Awards Award, Compasso d'Oro. Menzione d'Onore, Best of NeoCon, Wallpaper Awards, HD Boutique Awards, Miami Best of Boutique Awards. In Spain, received the 2007 National Design Award.

Andreu World ha sido reconocida internacionalmente con galardones como los Premios Red Dot Design Award, Compasso d'Oro. Menciones d'Onore, Best of NeoCon, Wallpaper Award, HD Boutique Awards, Best of Miami Boutique Awards. En España, recibió el Premio Nacional de Diseño 2007.

## 100% Sustainable wood Madera 100% sostenible



The mark of responsible forestry

100% of products made from solid wood are Forest Stewardship Council (FSC) certified. Products carrying the FSC® label are independently certified to assure consumers that the wood in their product comes from forests managed in socially, economically and environmentally responsible manners ensuring the resource for future generations.

El 100% de nuestros productos realizados en madera maciza están acreditados con el certificado FSC (Forest Stewardship Council Certification). Los productos con la etiqueta FSC® son independientemente certificados para asegurar a los clientes que proceden de bosques gestionados para cumplir las necesidades sociales, económicas y ambientalmente responsables de generaciones futuras.

Search our offering of FSC® (Forest Stewardship Council®) certified products at [www.andreuworld.com](http://www.andreuworld.com)

Busque nuestros productos con certificación FSC® (Forest Stewardship Council®) en [www.andreuworld.com](http://www.andreuworld.com)



016  
Alya



058  
Carlotta



094  
Flex Chair



138  
Happy



026  
Anna



066  
Carola



106  
Flex  
High Back



142  
Lake



036  
Beat



072  
Cloé



116  
Flex  
Corporate



148  
Lineal

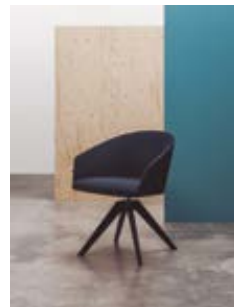

042  
Brandy



078  
Couvé



122  
Flex  
Executive



158  
Lineal  
Comfort



052  
Capri  
Lounge



088  
Duos

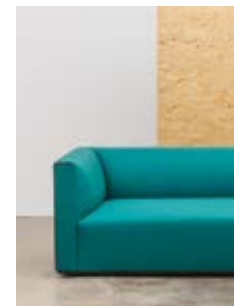

130  
Grand  
Raglan



168  
Lineal  
Corporate





**174  
Manfred**



**206  
Nuez**



**244  
Sail**



**282  
Smile**



**180  
Manila**



**216  
Pillow**



**252  
Serena**



**292  
Tauro**



**190  
Moody**



**222  
Raglan**



**258  
Siesta**



**300  
Valeria**



**034  
Noosa**



**232  
RDL**



**264  
Sit**



**306  
Zarina**



**194  
Nub**



**238  
Ronda**



**274  
Smart**

**Tables / Mesas**



**312  
Closed**



**346  
Plaza**



**370  
Reverse**



**400  
Tao**



**318  
Colors**



**350  
Quattro**



**376  
Reverse  
Occasional**



**404  
Uves**



**322  
Dual**

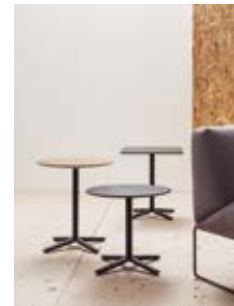

**354  
Quattro  
Occasional**



**382  
Reverse  
Conference  
Table**



**410  
Uves  
Occasional**



**330  
Dual  
Occasional**



**358  
Raglan  
Table**



**390  
Reverse  
Conference  
Lounge**



**414  
Tops**



**334  
Extra**



**362  
Radial  
Conference  
Table**



**394  
Sistema SP**

Alya is an invitation to comfort. The serene gesture that embraces us, inviting us to relax. It is developed ergonomically and suitable for contract spaces and residential areas alike thanks to its high versatility and the different versions of armchairs and lounge chairs. Alya expresses the value of our upholstered pieces and the richness provided by custom work.

Alya es una invitación al confort. El gesto sereno que nos abraza, y que nos invita al relax. Está desarrollada ergonómicamente y se adapta a ámbitos de contract o residenciales gracias a su gran polivalencia y sus diferentes versiones de sillón y butaca. Alya expresa el valor de nuestras piezas tapizadas y el confort que aporta el trabajo hecho a medida.

# Alya

by Lievore Altherr Molina







▲ **RS 1529**  
Upholstered ottoman.  
Reposapiés tapizado.

▲ **BU 1520**  
High back lounge chair with polished  
aluminum central swivel base.  
Butaca de respaldo alto con base  
central giratoria de aluminio pulido.

▲ **BU 1520**

◀ **BU 1522**  
High back lounge chair with a four-  
legged beech wood base.  
Butaca de respaldo alto y base de  
cuatro patas de madera maciza de  
haya.

**Waiting area**  
**Zona de espera**

► **BU 1521**  
High back lounge chair with a solid  
beech wood central swivel base.  
Butaca de respaldo alto y base  
central giratoria de madera maciza  
de haya.







◀ **BU 1523**

Low back lounge chair with a matte black aluminum central swivel base.  
Butaca de respaldo bajo y base central giratoria acabado negro mate.

**Waiting area**  
**Zona de espera**

▼ **BU 1530**

Upholstered high back lounge chair with optional rotating base.  
Butaca alta tapizada hasta abajo con opción de base giratoria.

**Waiting area**  
**Zona de espera**

▶ **BU 1524**

Low back lounge chair with a solid beech wood central swivel base and self-return system.  
Butaca de respaldo bajo con base central giratoria de madera maciza de haya con sistema de retorno.







◀ **SO 1535**

Upholstered armchair with steel sled base finished in polished white chrome.

Sillón con asiento y respaldo tapizado y base de patín de acero en acabado cromo blanco.

▼ **SO 1537**

Upholstered armchair with aluminum central base with five casters, swivel and pneumatic height adjustment and white finish.

Sillón con asiento y respaldo tapizado y base central giratoria de aluminio de cinco ruedas regulable en altura y acabado en blanco.

▼ **SO 1532**

Upholstered armchair with four star aluminum swivel base with self-return system finished in white aluminum.

Sillón tapizado con base central giratoria de cuatro aspas de aluminio con sistema de retorno y acabado aluminio blanco.



**Conference room**

**Sala de reunión**

▼ **SO 1532**

Upholstered armchair with four star aluminum swivel base with self-return system finished in polished aluminum.

Sillón tapizado con base central giratoria de cuatro aspas de aluminio con sistema de retorno y acabado aluminio pulido.





◀ **SO 1534**  
Upholstered armchair with four solid beech wood legs.  
Sillón tapizado con base de cuatro patas de madera maciza de haya.

▼ **SO 1533**  
Upholstered armchair with solid beech wood central swivel base.  
Sillón tapizado con base central giratoria de aspas de madera maciza de haya.

▼ **SO 1533**

**Residential  
Hogar**

▶ **SO 1534**





This collection of lounge chairs, easy chairs and sofas includes different lines (Lounge, Easy Chair and Corporate) that share the same aesthetic language. Anna and Noosa are two elegant options made in solid beech wood and with eye catching upholstery.

En la colección Anna de sillas, butacas, banquetas y sofás se integran distintas líneas (Lounge, Easy Chair y Corporate) que comparten un mismo lenguaje estético. Anna y Noosa son dos propuestas elegantes, realizadas en haya maciza y con el hilo conductor del tapizado.

# Anna

by Estudio Andreu





◀ **SI 1372**  
Upholstered chair. Low back version.  
Silla tapizada. Versión de respaldo bajo.

◀ **SI 1370**  
Upholstered chair. High back version.  
Silla tapizada. Versión de respaldo alto.

**Restaurant  
Restaurante**

◀ **SI 1372**

**Conference room  
Sala de reunión**

▼ **SI 1370**





► **SO 1373**  
Upholstered armchair.  
Low back version.  
Sillón tapizado.  
Versión de respaldo bajo.

▼ **SO 1371**  
Upholstered armchair. High  
back version.  
Sillón tapizado.  
Versión de respaldo alto.

**Restaurant  
Restaurante**

► **SO 1384**  
Upholstered armchair.  
Sillón tapizado.







**Anna Lounge**  
◀ SF 1407

Two seater  
upholstered sofa.  
Sofá tapizado de  
dos plazas.

◀ BU 1397  
Lounge chair.  
Butaca tapizada.

**Anna Lounge**  
Waiting area  
Zona de espera

◀ BU 1397  
◀ SF 1408

Three seater  
upholstered sofa.  
Sofá tapizado de  
tres plazas.

**Anna Corporate**  
▶ SO 1406

Upholstered armchair.  
Corporate version.  
Sillón tapizado.  
Versión corporate.

**Restaurant**  
Restaurante  
▼ SO 1384

Upholstered armchair.  
Sillón tapizado.





**Noosa**  
▶ **SI 1341**  
Stackable upholstered  
chair.  
Silla apilable tapizada.

**Conference room**  
**Sala de reunión**  
▼ **SI 1341**

**Conference room**  
**Sala de reunión**  
▶ **SI 1341**



The comfortable, beautiful and resilient Beat functions as either an ottoman or side chair. Beat was designed to be combined to create a cozy and inviting space. Available in three sizes, in a variety of fabrics and leather options, it adapts harmoniously into the most diverse environment.

Beat cumple una doble función, puede ser reposapiés o asiento auxiliar, y siempre resulta cómodo, bello y resistente. Está disponible en tres medidas, en una gran variedad de textiles o tapizados en piel y se adapta armónicamente a los ambientes más diversos.

# Beat

by Estudio Andreu





**Waiting area**  
**Zona de espera**

▼ **RS 0211**

Upholstered ottoman.  
Reposapiés tapizado.

▼ **RS 0213**

Upholstered ottoman.  
Reposapiés tapizado.

▼ **2x RS 0212**

Upholstered ottoman.  
Reposapiés tapizado.





**Waiting area**  
**Zona de espera**  
▼ **RS 0212**  
Upholstered ottoman.  
Reposapiés tapizado.  
▼ **RS 0213**  
Upholstered ottoman.  
Reposapiés tapizado.  
▼ 2x **RS 0211**  
Upholstered ottoman.  
Reposapiés tapizado.

**Waiting area**  
**Zona de espera**  
► **RS 0212**  
► **RS 0211**



The versatility and personality of the Brandy collection is now reinforced with a completely upholstered version with swivel base. As comfortable as it is versatile, Brandy is suitable for corporate and contract spaces or residential areas.

La polivalencia y personalidad de la colección Brandy se refuerza ahora con una versión completamente tapizada con la base giratoria. Tan comfortable como polivalente, Brandy se adapta a usos corporativos, de contract o residenciales.

# Brandy

by Lievore Altherr Molina





**Conference room  
Sala de reunión  
▼ SO 2999**

Upholstered armchair.  
Polished aluminum swivel  
base with self-return  
system.  
Sillón tapizado. Base  
central giratoria de  
aluminio pulido con  
sistema de retorno.







◀ **SO 3000**

Upholstered armchair. Polished aluminum central base with five casters. Swivel and pneumatic height adjustment.  
Sillón tapizado. Base central giratoria de aluminio pulido con cinco ruedas. Giratoria y regulable en altura.

▼ **SO 2994**

Upholstered armchair. Four-legged steel base.  
Sillón tapizado. Base de cuatro patas de acero.

▼ **SO 2993**

Upholstered armchair. Steel sled base.  
Sillón tapizado. Base de patín de acero.

**Workspace**

**Espacio de trabajo**

▶ **SO 2995**

Upholstered armchair. Steel cantilever base.  
Sillón tapizado. Base cantilever de acero.







◀ **SO 2997**  
Upholstered armchair.  
Swivel central base with  
solid beech wood legs.  
Sillón tapizado. Base  
central giratoria de  
madera maciza de haya.

**Home office**  
▼ **SO 2997**

**Cafeteria**  
**Cafetería**  
▶ **SO 2996**  
Upholstered armchair.  
Four solid beech wood  
legs.  
Sillón tapizado. Base de  
cuatro patas de madera  
maciza de haya.







**Waiting area  
Zona de espera**

**◀ BU 2991**

Upholstered lounge chair.  
Wood base.  
Butaca tapizada. Zócalo de  
madera.

**▶ BU 3001**

Upholstered lounge chair.  
Wood base.  
Butaca tapizada. Zócalo de  
madera.

**Waiting area  
Zona de espera**

**▼ BU 2991**

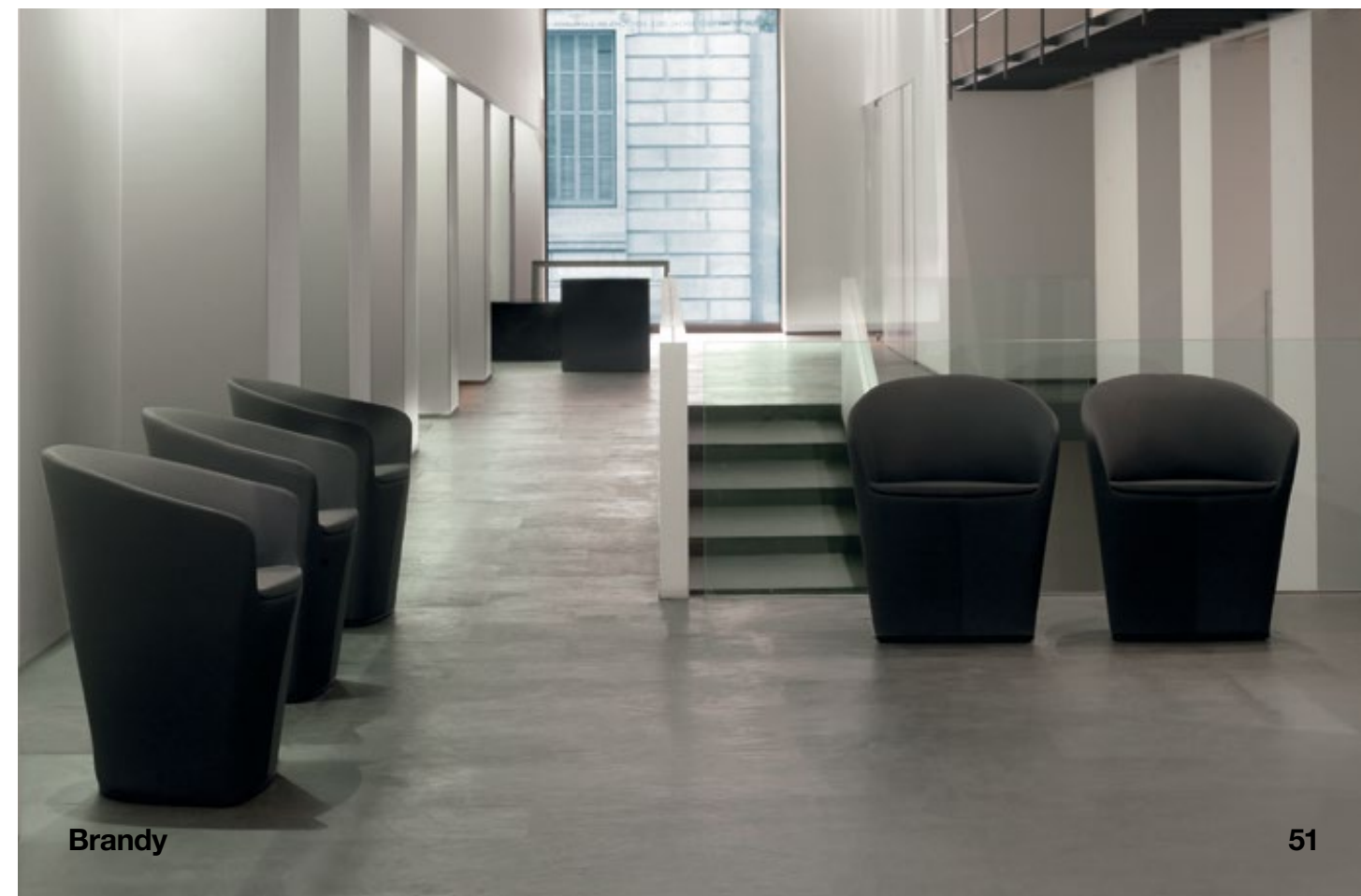

Capri lounge is a lounge chair with its own personality and focused on the comfort and high-end aesthetic. Like the great classic lounge chairs, it is extraordinarily comfortable and takes center stage in any space where it is installed. It conveys solidity, stability and harmony from an essential design.

Capri Lounge es una butaca con personalidad propia y centrada en el confort y la representatividad. Como las grandes butacas clásicas, es extraordinariamente confortable y toma el protagonismo en cualquier espacio donde se integra. Transmite solidez, estabilidad y armonía a partir de un diseño esencial.

## Capri Lounge

by Piergiorgio Cazzaniga





► **BU 1694**

Upholstered lounge chair. Aluminum arms with upholstered top face. Swivel four-star base with self-return finished in black.

Butaca tapizada. Brazos de aluminio con la parte superior tapizada. Base central giratoria de aluminio en negro de 4 aspas con sistema de retorno.

▼ **BU 1693**

Upholstered lounge chair. Upholstered arms. Swivel four-star base with self-return finished in black.

Butaca tapizada. Brazos tapizados. Base central giratoria de aluminio en negro de 4 aspas con sistema de retorno.

▼ **RS 1697**

Upholstered ottoman with aluminum swivel four-star base finished in black. Reposapiés tapizado con base central de aluminio de 4 aspas acabado en negro.

**Waiting area**  
**Zona de espera**

► **BU 1693**







◀ **BU 1692**

Upholstered lounge chair. Swivel four-star base with self-return finished in black.  
Butaca tapizada. Base central giratoria de aluminio de cuatro aspas con sistema de retorno en negro.

▼ **BU 1696**

Upholstered lounge chair. Upholstered arms. Steel sled base finished in black.  
Butaca tapizada. Brazos tapizados. Base de patín de acero en acabado negro.

▼ **BU 1695**

Upholstered lounge chair. Steel sled base finished in black.  
Butaca tapizada. Base de patín de acero en acabado negro.

**Waiting area**

**Zona de espera**

▶ **BU 1693**

Upholstered lounge chair. Upholstered arms. Swivel four-star base with self-return finished in black.  
Butaca tapizada. Brazos tapizados. Base central giratoria de aluminio en negro de cuatro aspas con sistema de retorno.



In any of its versions (chair, armchair and barstool) Carlotta is inviting yet resilient. This timeless design is noted for its versatility in both contract and residential applications and for its simple, classic lines.

En cualquiera de sus versiones (silla, sillón, butaca y banqueta) Carlotta es amable y resistente. Destaca por su versatilidad de usos, tanto en espacios de contract como residenciales, y por sus líneas sencillas y atemporales, su diseño es esencial.

# Carlotta

by Lievore Altherr Molina







◀ **SI 0915**  
Upholstered chair. Solid beech wood frame.  
Silla tapizada. Estructura de madera maciza de haya.

◀ **SO 0916**  
Upholstered armchair. Solid beech wood frame.  
Sillón tapizado. Estructura de madera maciza de haya.

**Waiting area**  
**Zona de espera**  
◀ **SO 0916**

**Residential**  
**Hogar**  
▼ **SO 0916**



**Carlotta**

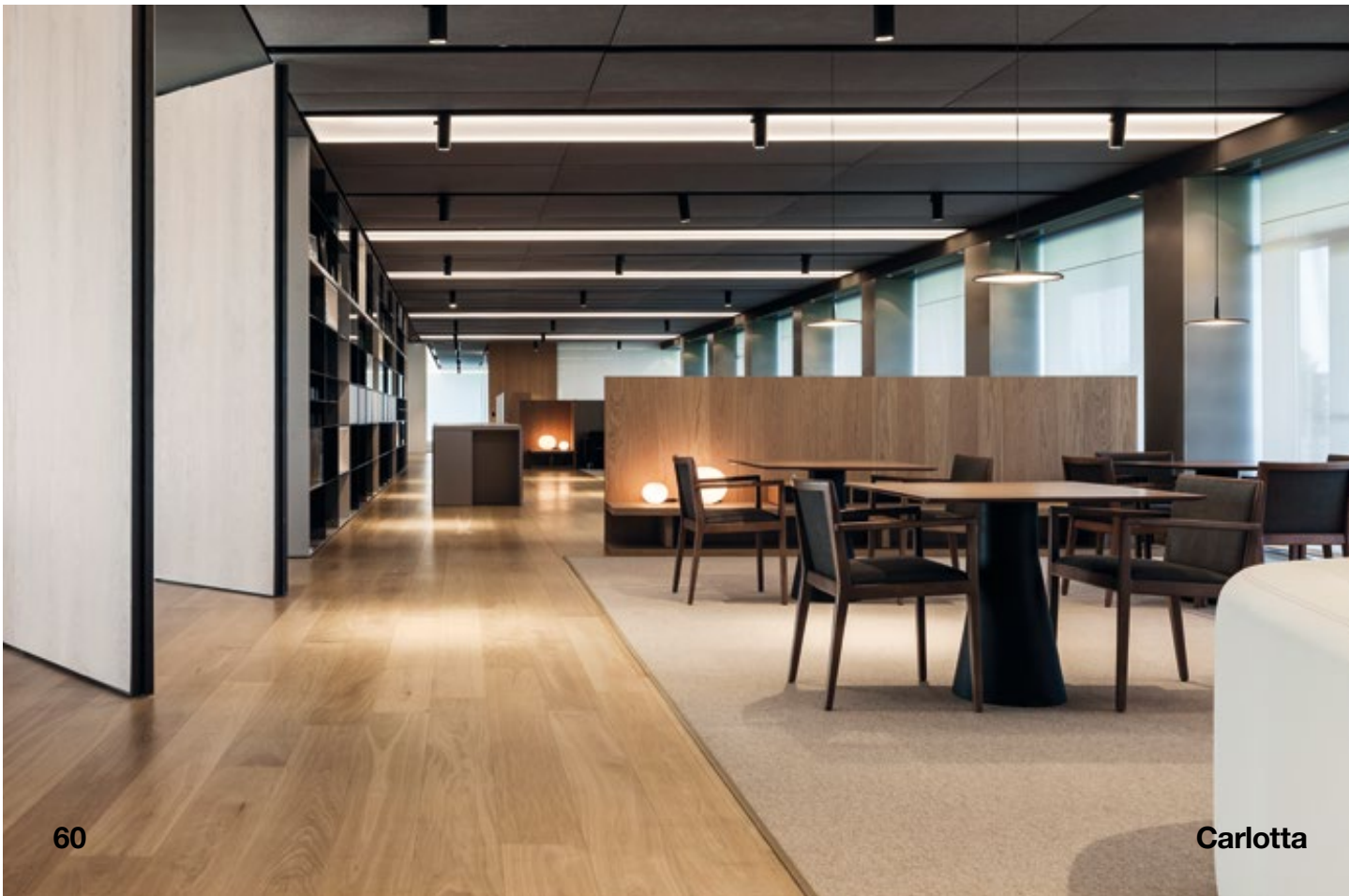





**Restaurant  
Restaurante**

**◀ SI 0991**

Upholstered chair. Solid beech wood frame. Small version.  
Silla tapizada. Estructura de madera maciza de haya.  
Versión pequeña.

**◀ BQ 0923**

Upholstered barstool. Solid beech frame.  
Banqueta alta tapizada.  
Estructura de madera maciza de haya.

**◀ BQ 0943**

Upholstered counter stool. Solid beech frame.  
Banqueta baja tapizada.  
Estructura de madera maciza de haya.

**Waiting area**

**Zona de espera**

**▼ BU 0926**

Upholstered lounge chair. Solid beech wood frame.  
Butaca tapizada. Estructura de madera maciza de haya.





**Cafeteria**  
**Cafeteria**  
▼ BU 0928

Upholstered lounge chair.  
Solid beech wood frame.  
Butaca tapizada.  
Estructura de madera  
maciza de haya.





Carola stands out for its elegance and incomparable wood finish. Both the upholstered and oak board seat versions convey warmth and comfort. It is the perfect addition to any bright open area.

Carola destaca por su línea esencial y por la textura inigualable de la madera. Es elegante, transmite calidez y resulta muy cómoda, tanto tapizada como con asiento de tablero de roble. Carola encaja a la perfección en ambientes diáfanos y luminosos.

## Carola

by Lievore Altherr Molina







◀ **SI 0905**  
Chair. Solid beech wood frame.  
Oak board seat.  
Silla. Asiento de tablero de roble.  
Estructura de madera maciza de haya.

**Cafeteria**  
**Cafetería**

▼ **SO 0902**  
Armchair. Solid beech wood frame. Oak board seat.  
Sillón. Asiento de tablero de roble. Estructura de madera maciza de haya.

**Workspace**  
**Espacio de trabajo**

▶ **SI 0906**  
Chair. Solid beech wood frame. Upholstered seat.  
Silla. Asiento tapizado. Estructura de madera maciza de haya.







**Library**  
**Biblioteca**

◀ **SO 0902**

Armchair. Solid beech wood frame. Oak board seat.  
Sillón. Asiento de tablero de roble. Estructura de madera maciza de haya.

**Cafeteria**  
**Cafetería**

▲ **SO 0908**

Armchair with solid beech wood backrest and frame and upholstered seat. Wider version.  
Sillón con asiento tapizado y respaldo y estructura de madera maciza de haya. Versión ancha.

▶ **SO 0907**

Armchair with solid beech wood backrest and frame and oak board seat. Wider version.  
Sillón con asiento de tablero de roble y respaldo y estructura de madera maciza de haya. Versión ancha.





Cloé provides all the comfort you expect from an upholstered seat and personality to transform any space into someplace special. The collection includes chairs, armchairs and lounge chairs available with two different backrest heights.

Cloé ofrece toda la comodidad que se espera de un asiento tapizado y toda la personalidad necesaria para convertir un espacio en algo diferente. La colección se compone de sillas y sillones con dos alturas diferentes de respaldo.

# Cloé

by Lievore Altherr Molina





**Cafeteria**

**Cafeteria**

**▼ SO 7018**

Upholstered armchair. Low back version.  
Sillón tapizado. Versión de respaldo bajo.

**Restaurant**

**Restaurante**

**► SI 7015**

Upholstered chair. Low back version.  
Silla tapizada. Versión de respaldo bajo.





► **SO 7020**  
Fully upholstered  
armchair.  
Sillón tapizado.

▼ **SI 7016**  
Upholstered chair. High back  
version.  
Silla tapizada. Versión de  
respaldo alto.

▼ **SO 7017**  
Upholstered armchair. Low  
back version.  
Sillón tapizado. Versión de  
respaldo bajo.

**Conference room**  
**Sala de reunión**

► **SO 7018**  
Upholstered armchair. Low  
back version.  
Sillón tapizado. Versión de  
respaldo bajo.

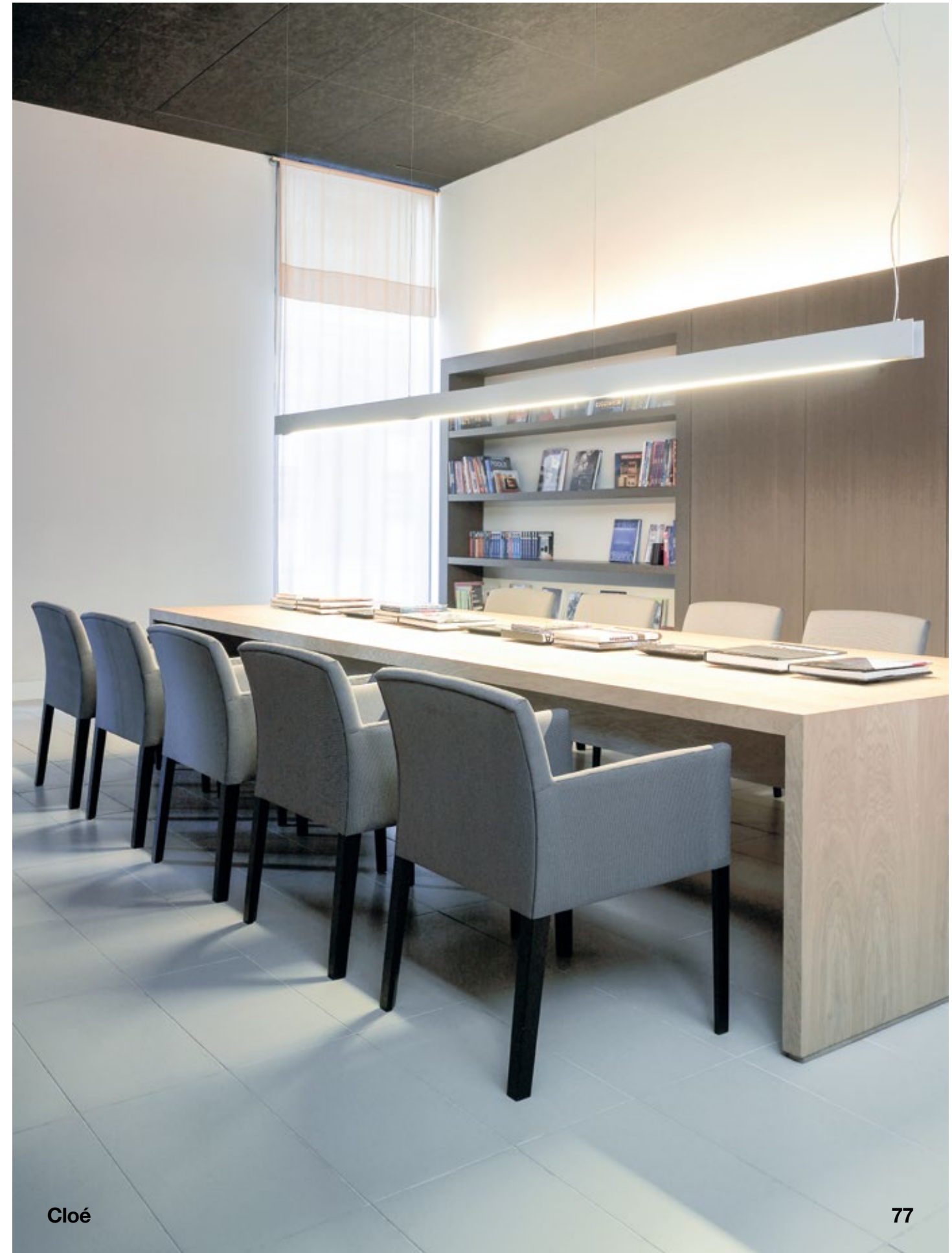



Comfort is communicated in this new design in a harmonious, dynamic and sensual manner. Couvé was born from a contemporary approach with respect to the traditional aesthetic of the classic sofa and lounge chair collections.

El confort se expresa en este nuevo diseño de un modo armónico, dinámico y sensual. Couvé nace como propuesta contemporánea respetuosa con la tradición estética de las colecciones clásicas de sofás y butacas.

# Couvé

by Piergiorgio Cazzaniga





**Waiting area**

**Zona de espera**

**▼ BU 1264**

Upholstered lounge chair.  
Butaca tapizada.

**▼ SF 1266**

Three-seater sofa upholstered sofa.  
Sofá tapizado de tres plazas.







◀ **BU 1264**  
Upholstered  
loung chair.  
Butaca tapizada.

▼ **SF 1266**  
Three-seater sofa  
upholstered sofa.  
Sofá tapizado de  
tres plazas.

**Waiting area**  
**Zona de espera**  
▶ **SF 1266**







**Waiting area  
Zona de espera**

**◀ SO 1267**

Armchair with upholstered seat and backrest and four-legged solid beech wood frame with optional casters.  
Sillón con asiento y respaldo tapizado y base de cuatro patas de madera maciza de haya con opción de ruedas.

**▼ SO 1267**



► **SO 1274**

Armchair with upholstered seat and backrest and four-legged solid beech wood frame with optional casters.  
Sillón con asiento y respaldo tapizado y base de cuatro patas de madera maciza de haya con opción de ruedas.

**Waiting area**

**Zona de espera**

▼ **SF 1266**

Three-seater sofa upholstered sofa.

Sofá tapizado de tres plazas.

▼ **SF 1265**

Two-seater sofa upholstered sofa.

Sofá tapizado de dos plazas.

▼ **BU 1264**

Lounge chair.

Butaca.



**Workspace**  
**Zona de trabajo**

▼ **BU 1276**

Lounge chair with upholstered seat and backrest and four-legged solid beech wood frame.  
Butaca con asiento y respaldo tapizado y base de cuatro patas de madera maciza de haya.

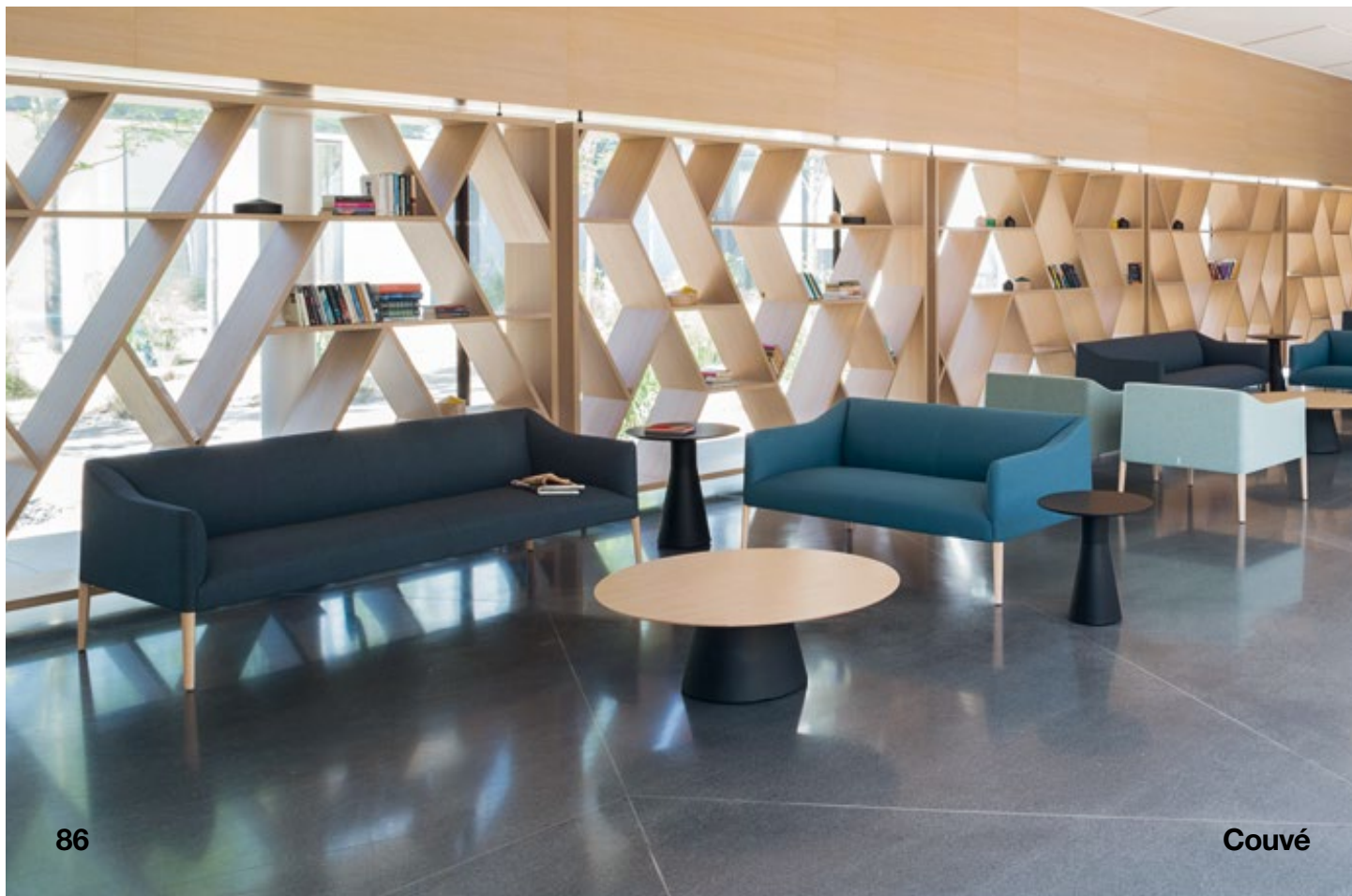
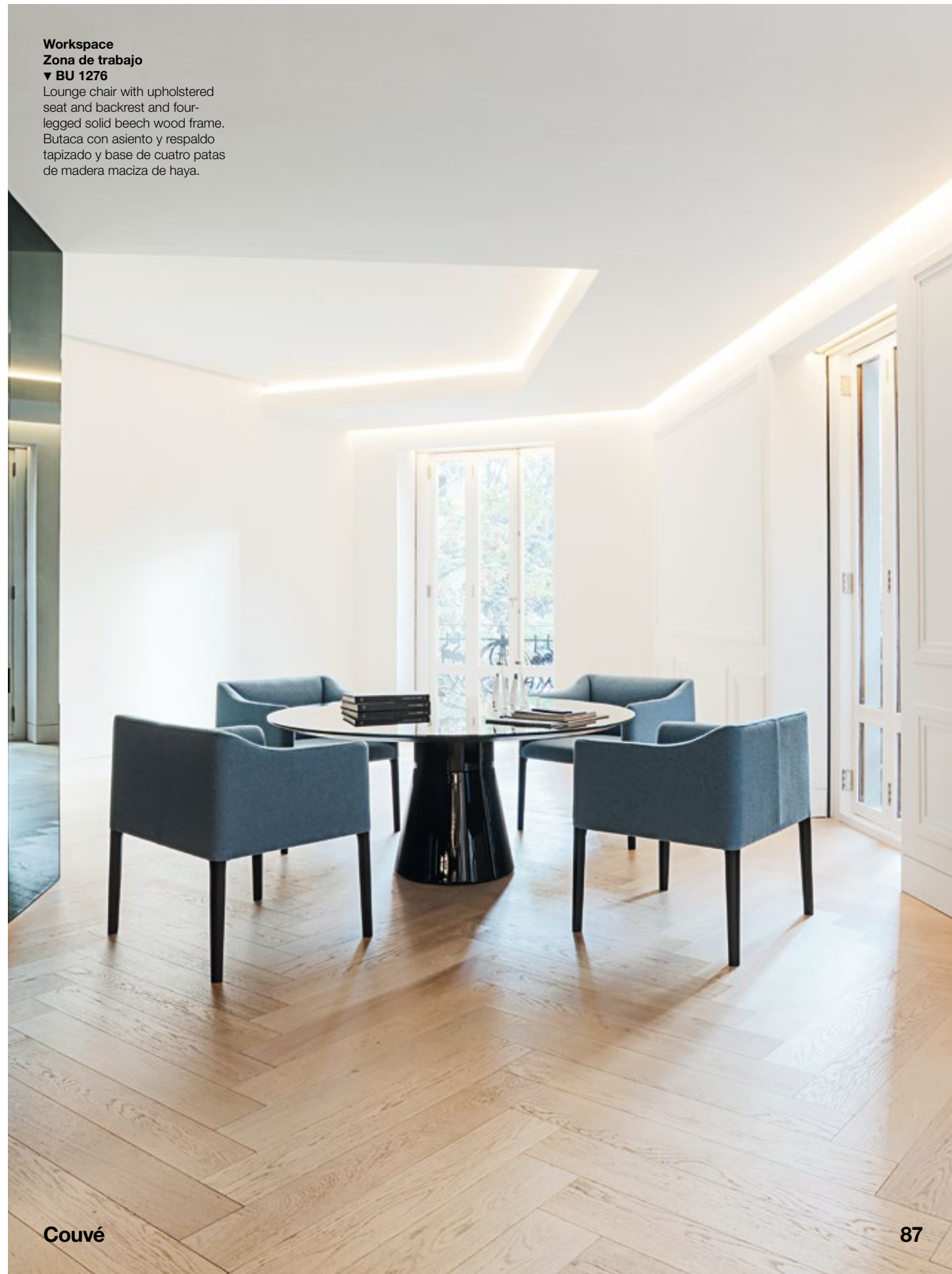



Duos is characterized by its formal synthesis and functionality. It is an essential, stackable design and it is available as a chair and armchair with upholstered or wooden versions. Duos is the result of an intense formal search based on new constructive solutions, which are synthesized in a light, timeless and very comfortable collection.

Duos se caracteriza por su síntesis formal y funcionalidad. Es un diseño esencial, apilable y está disponible como silla y sillón con versiones tapizadas o en madera. Duos es el resultado de una intensa búsqueda formal a partir de nuevas soluciones constructivas, que se sintetizan en una colección ligera, atemporal y muy confortable.

## Duos

by Jasper Morrison







◀ **SI 2750**  
Stackable chair with beech plywood board seat and backrest and solid beech wood frame.  
Silla apilable con asiento y respaldo de tablero de haya y estructura de madera maciza de haya.

▼ **SO 2753**  
Stackable armchair with upholstered seat and backrest and solid beech wood frame.  
Sillón apilable con asiento y respaldo tapizado y estructura de madera maciza de haya.

▼ **SI 2754**  
Stackable chair with upholstered seat, wood backrest and solid beech wood frame.  
Silla apilable con asiento tapizado, respaldo de tablero contrachapado de haya y estructura de madera maciza de haya.

▼ **SI 2752**  
Stackable chair with upholstered seat and backrest and solid beech wood frame.  
Silla apilable con asiento y respaldo tapizado y estructura de madera maciza de haya.

**Cafeteria**  
**Cafetería**  
▶ **SI 2750**





**Cafeteria**

**Cafetería**

**▼ SI 2750**

Stackable chair with beech plywood board seat and backrest and solid beech wood frame.

Silla apilable con asiento y respaldo de tablero de haya y estructura de madera maciza de haya.





A chair intended to be used for work or in a large assembly space must be as durable as it is comfortable and attractive. The Flex Chair meets and exceeds these requirements with its versatile design and numerous offering of accessories (writing tablets, linking and numbering systems). This chair is the benchmark for projects that demand excellence.

Una silla de trabajo o destinada a grandes audiencias necesita ser tan resistente como confortable y atractiva. Flex Chair reúne estas características y cuenta con un gran número de accesorios (sistemas de escritura, unión y numeración...) que la convierten en un referente para proyectos polivalentes.

## Flex Chair

by Piergiorgio Cazzaniga





► SI 1300

Stackable thermo-polymer chair.  
Steel sled base.  
Silla apilable con carcasa de termo-  
polímero. Base de patín de acero.

**Workspace**

**Espacio de trabajo**

▼ SI 1302

Stackable thermo-polymer chair.  
Four steel legs.  
Silla apilable con carcasa de  
termopolímero.  
Base de cuatro patas de acero.



**Workspace**  
**Espacio de trabajo**

▼ SI 1314

Thermo-polymer chair with a  
Four-legged solid beech wood  
base. Upholstered seat pad.  
Silla con carcasa de  
termopolímero con base  
de cuatro patas de madera  
maciza de haya. Asiento con  
plafón tapizado.

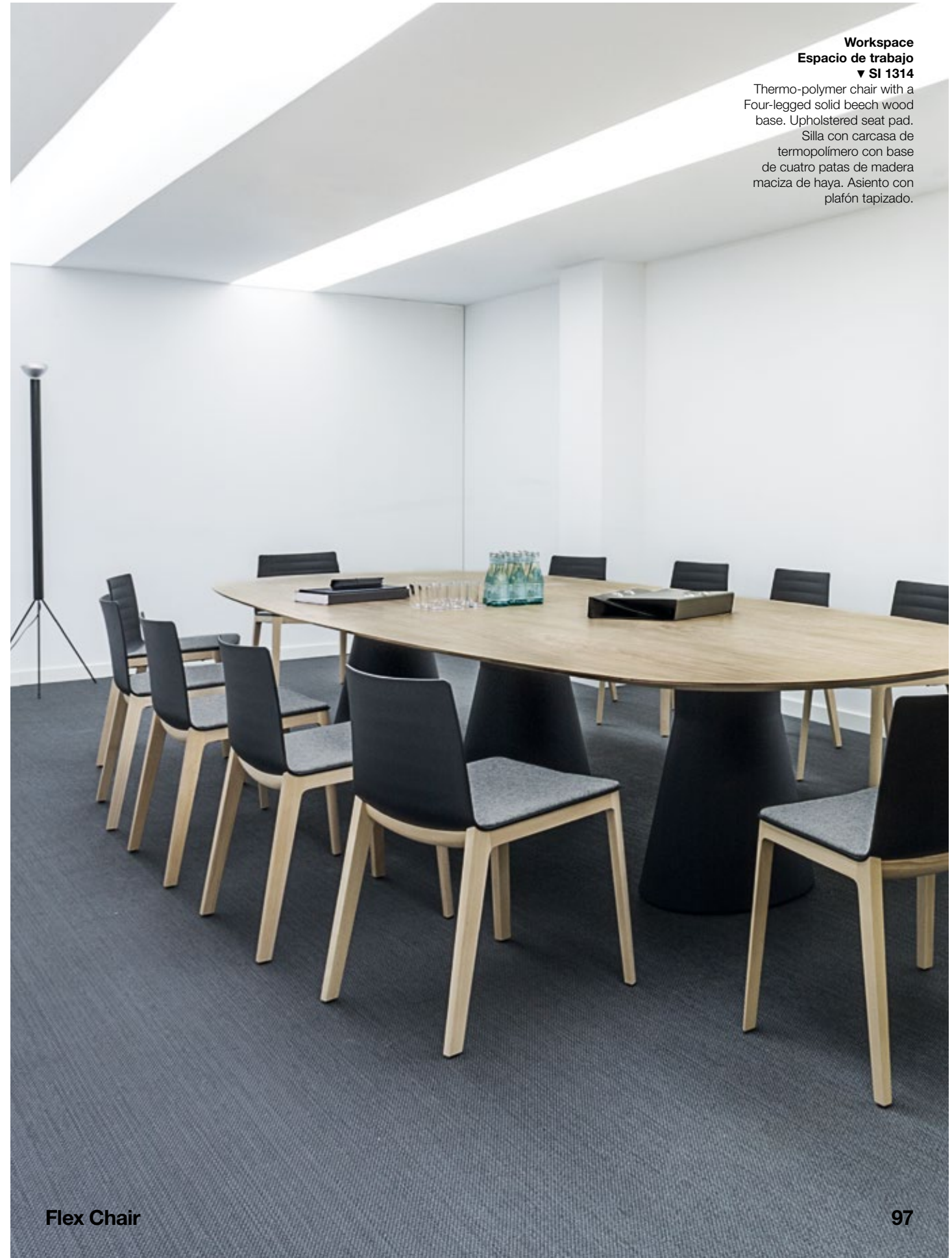



► **SO 1301**

Stackable thermo-polymer armchair. Steel sled base.  
Sillón apilable con carcasa de termopolímero. Base de patín de acero.

**Conference room**

**Sala de reunión**

▼ **SO 1301**

Stackable armchair with a steel sled base in polished chrome finish. Thermo-polymer seat and backrest.  
Sillón apilable con carcasa de termopolímero y base de patín de varilla de acero acabado cromo brillo.

**Home office**

► **SI 1300**

Stackable upholstered chair. Steel sled base.  
Silla apilable con carcasa tapizada. Base de patín de acero.

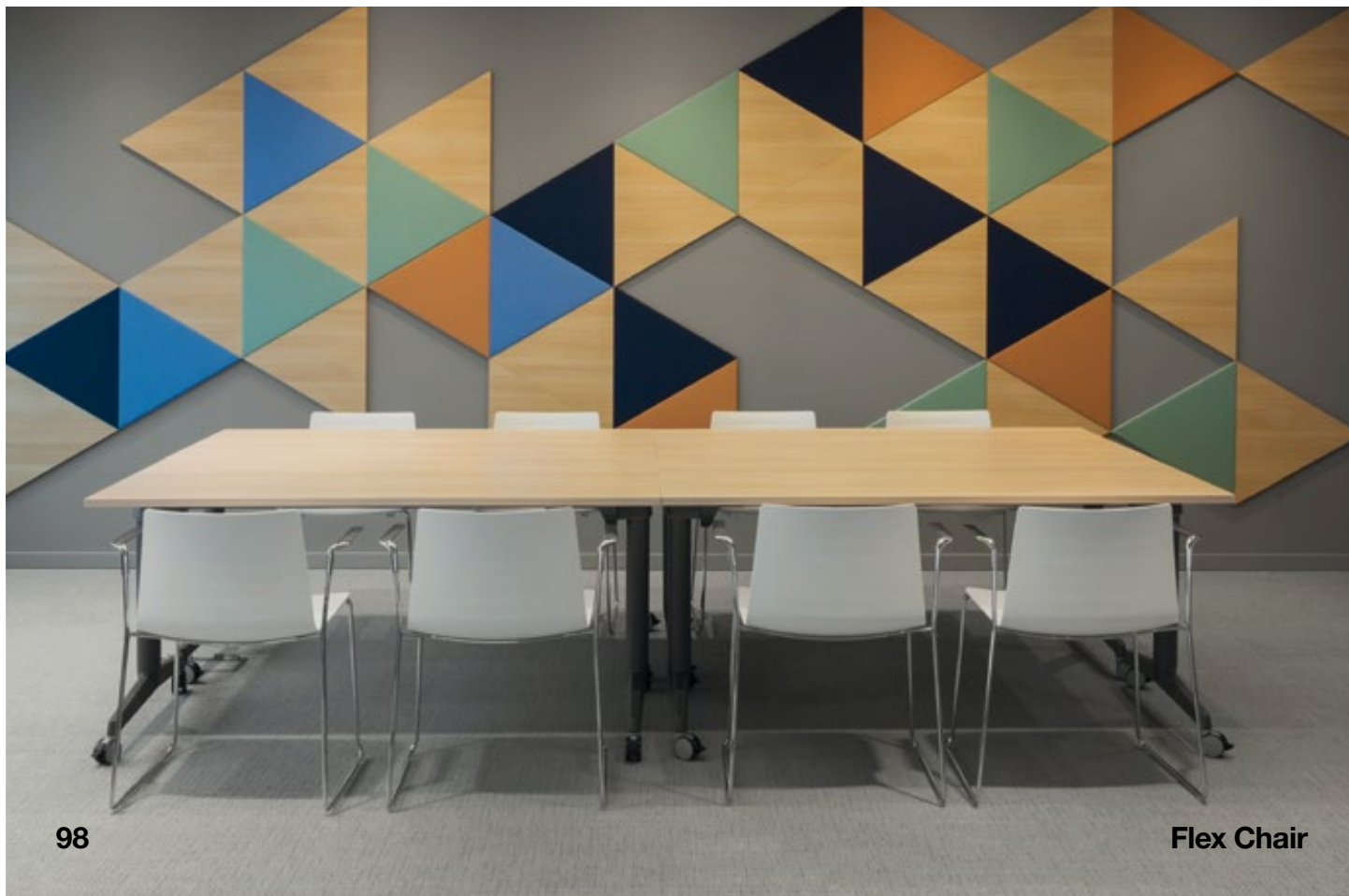





▲ **SI 1359\***  
 Upholstered chair with cantilever base finished in black.  
 Silla tapizada con base cantiléver de acero en acabado negro.

▲ **SO 1305\***  
 Upholstered armchair. Black aluminum swivel central base and return system.  
 Sillón con carcasa tapizada. Base central giratoria de aluminio negro con sistema de retorno.

► **SO 1307**  
 Upholstered armchair. Central base with five casters finished in black.  
 Sillón tapizado. Base central con cinco ruedas y acabado negro.

**Conference room**  
**Sala de reunión**  
 ► **SI 1304**  
 Upholstered chair. Polished aluminum swivel central base and return system.  
 Sillón con carcasa tapizada. Base central giratoria de aluminio pulido con sistema de retorno.

\* Optional parallel stitching upholstery.  
 \* Costuras paralelas opcionales en el tapizado.



Flex Chair



Flex Chair



**Workspace**  
**Espacio de trabajo**

► **BQ 1316 \***

Barstool. Four-legged steel tube swivel base with polished chrome finish. Upholstered shell.  
Banqueta alta. Base giratoria de cuatro patas de acero y acabado cromo brillo. Carcasa tapizada

▼ **BQ 1309 \***

Stackable thermo-polymer counter stool. Four steel sled base.  
Banqueta baja apilable de termopolímero. Base de cuatro patas de acero.

▼ **BQ 1312**

Stackable thermo-polymer barstool. Steel sled base.  
Banqueta alta apilable de termopolímero. Base de patín de acero.

**Cafeteria**

**Cafetería**

► **BQ 1316**





► **BQ 1336 \***

Barstool with a four-legged solid beech wood base. Upholstered shell. 45mm/1.75in. seating width. Banqueta alta con base de cuatro patas de madera maciza de haya. Carcasa tapizada. 45mm. anchura de asiento.

▼ **BQ 1333 \***

Stackable counter stool with steel sled base in black finish. Upholstered shell. 45mm/1.75in. seating width. Banqueta baja apilable con base de patín de acero en acabado negro. Carcasa tapizada 45mm anchura de asiento.

▼ **BQ 1332**

Stackable barstool with steel sled base in black finish. Thermopolymer shell. 45mm/1.75in. seating width. Banqueta alta apilable con base de patín de acero en acabado negro. Carcasa de termopolímero. 45mm anchura de asiento.

▼ **BQ 1330 \***

Barstool with four tubular steel legs in black finish. Upholstered shell. 45mm/1.75in. seating width. Banqueta con base de cuatro patas de acero en acabado negro. Carcasa tapizada. 45mm anchura de asiento.

\* Optional parallel stitching upholstery.  
\* Costuras paralelas opcionales en el tapizado.



**Cafeteria**

**Cafetería**

▼ **SI 1302**

Stackable thermo-polymer chair. Four steel legs. Silla apilable con carcasa de termopolímero. Base de cuatro patas de acero.

▼ **BQ 1334 \***

Barstool with four-legged steel swivel base in black finish. Thermopolymer shell. 45mm/1.75in. seating width. Banqueta alta con base giratoria de cuatro patas de acero y acabado negro. Carcasa de termopolímero. 45mm. anchura de asiento.





The Flex High Back has the same simplicity and versatility as the Flex Collection however its slightly higher backrest that provides it with a distinctive aesthetic and own personality. It's the perfect office chair and an elegant option for restaurant projects or large assemblies.

La serie Flex High Back destaca por su sobriedad, su versatilidad de usos y un respaldo ligeramente más alto que le proporcionan una estética diferenciada y con personalidad propia. Es la perfecta silla de oficina y también una solución elegante en proyectos de hostelería o grandes colectividades.

## Flex High Back

by Piergiorgio Cazzaniga





► **SI 1659 \***

Upholstered chair. Swivel central base with five casters and height adjustment.  
Silla tapizada. Base central giratoria con cinco ruedas, regulable en altura.

▼ **SI 1656 \***

Upholstered chair. Swivel central base with five casters and height adjustment.  
Silla tapizada. Base central giratoria con cinco ruedas, regulable en altura.

▼ **SO 1644 \***

Upholstered armchair. Swivel central base and return system.  
Sillón tapizado. Base central giratoria con sistema de retorno.

\* Optional parallel stitching upholstery.  
\* Costuras paralelas opcionales en el tapizado.



**Conference room**

**Sala de reunión**

▼ **SI 1638 \***

Upholstered chair. Central base with four casters.  
Silla tapizada. Base central con cuatro ruedas.







◀ **SO 1644 \***  
 Upholstered armchair. Swivel central base and return system.  
 Sillón con carcasa tapizada. Base central giratoria con sistema de retorno.

▼ **SO 1610 \***  
 Stackable upholstered armchair. Four steel legs. Matte black finish.  
 Sillón apilable con carcasa tapizada. Base de cuatro patas de acero. Acabado negro mate.

▼ **SI 1621**  
 Stackable thermo-polymer chair. Steel sled base.  
 Silla apilable con carcasa de termopolímero. Base de patín de acero.

▼ **SI 1621**

**Workspace  
 Espacio de trabajo**

► **SI 1601**  
 Thermo-polymer chair. Four-legged solid beech wood base.  
 Silla con carcasa de termopolímero. Base de cuatro patas de madera maciza de haya.

\* Optional parallel stitching upholstery.  
 \* Costuras paralelas opcionales en el tapizado.





▼ **SO 1633**

Thermo-polymer armchair with cantilever base finished in bright chrome.

Sillón de termopolímero con base cantiléver de acero en acabado cromo brillo.

▼ **SO 1633\***

Upholstered armchair with cantilever base finished in bright chrome.

Sillón tapizado con base cantiléver de acero en acabado cromo brillo.

**Workspace**

**Espacio de trabajo**

► **SO 1633\***

Upholstered chair with cantilever base finished in black.

Silla tapizada con base cantiléver de acero en acabado negro.

\* Optional parallel stitching upholstery.

\* Costuras paralelas opcionales en el tapizado.





► **BQ 1668**

Barstool. Four-legged steel tube swivel base with polished chrome finish.  
Banqueta alta. Base giratoria de cuatro patas de acero y acabado cromo brillo.

▼ **BQ 1666 \***

Barstool. Four solid beech legs. Upholstered shell.  
Banqueta alta. Cuatro patas de madera maciza de haya. Carcasa tapizada.

▼ **BQ 1672 \***

Counter stool. Four solid beech legs. Upholstered shell.  
Banqueta baja. Cuatro patas de madera maciza de haya. Carcasa tapizada.



\* Optional parallel stitching upholstery.  
\* Costuras paralelas opcionales en el tapizado.



Waiting area

Zona de espera

▼ **BQ 1677 \***

Barstool. Stackable upholstered barstool. Steel sled base.  
Banqueta alta apilable tapizada. Base de patín de acero.

\* Optional parallel stitching upholstery.  
\* Costuras paralelas opcionales en el tapizado.





The most luxurious offering of the Flex collection, the Flex Corporate has a fully upholstered seat and backrest. The wider seat, higher backrest and thicker foam increase comfort and opulence.

Es el nivel más alto en cuanto a representatividad de la colección Flex. Tiene la carcasa completamente tapizada, un asiento más ancho, un respaldo más alto y una espuma de mayor espesor para incrementar su comodidad y confort.

## Flex Corporate

by Piergiorgio Cazzaniga





**Office**

**Oficina**

► **SO 1611 \***

Stackable armchair with four tubular steel legs and finished in polished chrome. Fully upholstered seat and backrest.  
Sillón apilable con carcasa tapizada y base de cuatro patas de tubo de acero en acabado cromo brillo.

▼ **SO 1611 \***

▼ **SI 1603 \***

Stackable chair with four tubular steel legs and finished in black. Fully upholstered seat and backrest.  
Silla apilable con carcasa tapizada y base de cuatro patas de tubo de acero en acabado negro.

**Conference room**

**Sala de reunión**

► **SI 1639 \***

Chair with a four star central aluminum swivel base with self-return system and finished in black. Fully upholstered seat and backrest.  
Silla con carcasa tapizada y base central giratoria de aluminio de cuatro aspas con sistema de retorno en negro.

\* Optional parallel stitching upholstery.

\* Costuras paralelas opcionales en el tapizado.





**Workspace**  
**Espacio de trabajo**

► **SI 1639\***

Upholstered chair with a four star central aluminum swivel base. Finished in matte black.  
Silla tapizada y base central giratoria de cuatro aspadas de aluminio acabado en negro.

► **SO 1660\***

Upholstered armchair. Swivel polished aluminum base with five casters, height adjustment and finished in polished aluminum.

Sillón tapizado. Base central giratoria con cinco ruedas, regulable en altura y acabado aluminio pulido.

▼ **SO 1660\***

**Workspace**  
**Espacio de trabajo**

► **SO 1634\***

Upholstered armchair with cantilever base finished in black.

Sillón tapizado con base cantiléver de acero en acabado negro.



\* Optional parallel stitching upholstery.

\* Costuras paralelas opcionales en el tapizado.





Thanks to its generous proportions and studied comfort, this collection exceeds the requirements of conference seating through its attractive and timeless design. Available in three backrest heights and central or caster base options.

Gracias a sus generosas dimensiones y a su estudiado confort, es capaz de satisfacer las necesidades de su función operativa a través de un diseño atractivo y atemporal. Propone tres alturas de respaldo y opciones de base central o ruedas.

## Flex Executive

by Piergiorgio Cazzaniga





**Meeting room**  
**Sala de reunión**  
**▼ SO 1861\***

High back armchair with upholstered shell and back finished in walnut veneer. Central swivel base with five casters. Height adjustable.

Sillón de respaldo alto con carcasa tapizada y respaldo en madera de nogal. Base central giratoria de cinco ruedas. Altura regulable.

\* Optional parallel stitching upholstery.

\* Costuras paralelas opcionales en el tapizado.





► **SI 1856\***

Low back chair. Upholstered shell. Aluminium swivel base with central column and five casters, height adjustable and finished in black aluminum.  
Silla de respaldo bajo. Carcasa tapizada. Base central de aluminio con 5 ruedas, giratoria y regulable en altura en acabado de aluminio negro.

▼ **SO 1860\***

Intermediate back armchair with upholstered shell and adjustable central swivel base with five casters finished in black.  
Sillón de respaldo intermedio con carcasa tapizada y base central giratoria con cinco ruedas regulable en altura en acabado negro.

▼ **SO 1845\***

Intermediate back armchair with upholstered shell and aluminum swivel four-star base with self-return and finished in black.  
Sillón de respaldo intermedio con carcasa tapizada y base central giratoria de aluminio de cuatro aspas con sistema de retorno en acabado negro.

\* Optional parallel stitching upholstery.  
\* Costuras paralelas opcionales en el tapizado.



► **SO 1846\***

High back armchair. Upholstered shell. Aluminium swivel base with central column and four-star foot, with self return system and polished aluminum finish. Back finish in walnut veneer.  
Sillón de respaldo alto. Carcasa tapizada. Base central de aluminio de cuatro aspas, con sistema de retorno en acabado aluminio pulido. Respaldo en madera de nogal.

▼ **SO 1846\***

High back armchair. Upholstered shell. Aluminium swivel base with central column and four-star foot, with self return system and black finish.  
Sillón de respaldo alto. Carcasa tapizada. Base central de aluminio de cuatro aspas, con sistema de retorno en acabado negro. Respaldo en madera de nogal.

\* Optional parallel stitching upholstery.  
\* Costuras paralelas opcionales en el tapizado.



126



Flex Executive



Flex Executive

127



**Waiting area  
Zona de espera**

► **BU 1893\***

Low back lounge chair with arms, upholstered shell and aluminum swivel four-star base with self-return and finished in black.

Butaca de respaldo bajo con brazos, carcasa tapizada y base central giratoria de aluminio de cuatro aspas con sistema de retorno en acabado negro.

▼ **BU 1895\***

High back lounge chair with arms. Upholstered shell. Aluminium swivel base with central column and four-star foot, with self return system and black finish. Back finish in Walnut veneer.

Butaca de respaldo alto con brazos. Carcasa tapizada. Base central de aluminio de cuatro aspas, con sistema de retorno en acabado negro. Respaldo en madera de Nogal.

▼ **BU 1892\***

Low back lounge chair. Upholstered shell. Aluminium swivel base with central column and four-star foot, with self return system and black finish.

Butaca de respaldo bajo. Carcasa tapizada. Base central de aluminio de cuatro aspas, con sistema de retorno en acabado negro.

▼ **BU 1893\***

Low back lounge chair. Upholstered shell. Aluminium swivel base with central column and four-star foot, with self return system and polished aluminum finish.

Butaca de respaldo bajo. Carcasa tapizada. Base central de aluminio de cuatro aspas, con sistema de retorno en acabado aluminio pulido.

\* Optional parallel stitching upholstery.

\* Costuras paralelas opcionales en el tapizado.



**Waiting area  
Zona de espera**

▼ **BU 1895\***

High back lounge chair. Upholstered shell. Aluminium swivel base with central column and four-star foot, with self return system and black finish. Back finish in Walnut veneer.

Butaca de respaldo alto. Carcasa tapizada. Base central de aluminio de cuatro aspas, con sistema de retorno en acabado negro. Respaldo en madera de nogal.

\* Optional parallel stitching upholstery.

\* Costuras paralelas opcionales en el tapizado.





Grand Raglan is a collection of sofas and lounge chairs designed to be integrated in large waiting spaces, in lobbies where sophistication is demanded. Its geometric designs permits the unification of the place where it is located, creating volumes and sets of compositions that fill the space in different group configurations.

Grand Raglan es una colección de butacas y sofás diseñada para integrarse en grandes espacios de espera, en vestíbulos donde se exige sofisticación. Sus diseños geométricos permiten la unificación del lugar donde se encuentra, creando volúmenes y conjuntos de composiciones que llenan el espacio en diferentes configuraciones de grupo.

## Grand Raglan

by Piergiorgio Cazzaniga





**Waiting area  
Zona de espera**

**▼ BU 2114**

Upholstered lounge chair with steel plinth base finished in black. Black piping.  
Butaca tapizada y base de zócalo de acero negro. Ribete negro.

**▼ SF 2116**

Upholstered Three-seater sofa and steel plinth base finished in black. Black piping.  
Sofá de tres plazas tapizado y base de zócalo de acero negro. Ribete negro.



**Waiting area  
Zona de espera**

**▼ SF 2115**

Upholstered two-seater sofa and steel plinth base finished in black. Black piping.  
Sofá de dos plazas tapizado y base de zócalo de acero negro. Ribete negro.

**▼ SF 2116**

Upholstered Three-seater sofa and steel plinth base finished in black. Black piping.  
Sofá de tres plazas tapizado y base de zócalo de acero negro. Ribete negro.

**► SF 2116**

**► SF 2115**







◀ **BU 2114**  
Upholstered lounge chair with steel plinth base finished in black. Black piping.  
Butaca tapizada y base de zócalo de acero negro.  
Ribete negro.

▼ **BU 2114**  
▼ **SF 2116**  
Upholstered Three-seater sofa and steel plinth base finished in black. Black piping.  
Sofá de tres plazas tapizado y base de zócalo de acero negro. Ribete negro.

▼ **SF 2115**  
Upholstered two-seater sofa and steel plinth base finished in black. Black piping.  
Sofá de dos plazas tapizado y base de zócalo de acero negro. Ribete negro.

▶ **SF 2116**





Light weight, calm and resilient. Happy is the perfect side chair for any residential or public space. The chair is stackable and the armchair has added comfort without losing its lightness. Both versions accentuate the warmth and grain of solid beech wood.

Ligera, tranquila y resistente. Happy es el perfecto asiento auxiliar de ambientes residenciales y espacios públicos. La silla es apilable y el sillón incorpora un plus de comodidad sin perder en ligereza; ambos expresan la calidez y la textura de la madera de haya maciza.

# Happy

by Lievore Altherr Molina





► **SO 0378**

Armchair. Upholstered seat. Oak board backrest.  
Sillón. Asiento tapizado. Respaldo de tablero de roble.

**Cafeteria**

**Cafetería**

▼ **SI 0374**

Stackable chair. Oak board seat and backrest.  
Silla apilable. Asiento y respaldo de tablero de roble.

**Conference room**

**Sala de reunión**

► **SO 0375**

Armchair. Oak board seat and backrest.  
Sillón. Asiento y respaldo de tablero de roble.





Its apparent simplicity is the result of an exhaustive work on the value and timelessness of wood. It is a contemporary reinterpretation of the mediterranean classic chairs developed from the work of cabinetmaking; a piece that combines lightness, constructive quality and durability.

Su aparente sencillez formal es el resultado de un exhaustivo trabajo en torno al valor y la atemporalidad de la madera. Es una reinterpretación contemporánea de las sillas clásicas mediterráneas desarrolladas desde el trabajo de ebanistería; una pieza que combina ligereza, calidad constructiva y resistencia.

## Lake

by Piergiorgio Cazzaniga





**Restaurant  
Restaurane**

▼ SI 0653

Stackable chair with woven seat that matches wood tone and backrest and solid beech wood frame.

Silla apilable con asiento de cuerda en color al tono de la madera y respaldo y estructura de madera maciza de haya.







◀ **SI 0654**

Stackable chair with upholstered seat, backrest and solid beech wood frame.  
Silla apilable con asiento tapizado y respaldo y estructura de madera maciza de haya.

▼ **SI 0653**

Stackable chair with woven seat that matches wood tone and backrest and solid beech wood frame.  
Silla apilable con asiento de cuerda en color al tono de la madera y respaldo y estructura de madera maciza de haya.

▼ **SI 0652**

Stackable chair with board seat and backrest and solid beech wood frame.  
Silla apilable con asiento de tablero de madera y respaldo y estructura de madera maciza de haya.

**Restaurant  
Restaurane**  
▶ **SI 0653**



146



Lake



Lake

147



The entire Lineal Collection is based on a simple concept: a soft curve with a single line structure. This perfect synthesis is achieved through a curved contour of oak wood, suspended in the air by a fine metal sled base.

Toda la colección Lineal parte de una imagen muy clara: una suave curva enmarcada por una línea. Esta síntesis perfecta se logra mediante un trazo de madera de roble curvada, suspendida en el aire gracias a una fina línea de metal.

# Lineal

by Lievore Altherr Molina





**Restaurant  
Restaurante**  
▼ SI 0584

Stackable chair. Upholstered seat and backrest. Steel sled base.  
Silla apilable. Carcasa tapizada. Base de patín de acero.







◀ **SI 0582**  
Stackable chair. Oak board seat and backrest. Steel sled base.  
Silla apilable. Carcasa de tablero de roble. Base de patín de varilla de acero.

**Residencial  
Hogar**

▼ **SO 0585**  
Stackable armchair. Upholstered seat and backrest. Steel sled base.  
Sillón apilable. Carcasa tapizada. Base de patín de varilla de acero.

**Cafetería  
Cafetería**

▶ **SI 0582**







**Educational  
Educativa**

◀ **SI 0584**

Upholstered stackable chair. Steel sled base.  
Silla apilable con carcasa tapizada.  
Base de patín de varilla de acero.

▶ **SO 0763**

Armchair. Upholstered seat and backrest. Four-legged solid beech wood base.  
Sillón. Carcasa tapizada. Base de cuatro patas de madera maciza de haya.

**Restaurant  
Restaurante**

▼ **SI 0760**

Chair. Oak seat and backrest. Four-legged solid beech wood base.  
Silla. Carcasa de tablero de roble.  
Base de cuatro patas de madera maciza de haya.







◀ **BU 0589**  
Stackable lounge chair. Upholstered shell.  
Steel sled base.  
Butaca apilable. Carcasa tapizada. Base de patín de varilla de acero.

**Waiting area**  
**Zona de espera**

▼ **BU 0588**  
Stackable lounge chair. Upholstered shell.  
Steel sled base.  
Butaca apilable. Carcasa tapizada. Base de patín de varilla de acero.

**Workspace**  
**Espacio de trabajo**

▶ **BQ 0642**  
Barstool with oak plywood shell and four-legged steel swivel base. Upholstered shell pad.  
Banqueta alta con carcasa de tablero de roble y base giratoria de 4 patas de acero. Asiento y respaldo plafonado.

**Cafeteria**

**Cafetería**  
▼ **BQ 0591**  
Upholstered seat and backrest. Steel sled base.  
Banqueta. Carcasa tapizada. Base de patín de varilla de acero.





Lineal Comfort, along with Lineal and Lineal Corporate, is one of the largest and most versatile collection of chairs, armchairs, lounge chairs and barstools. While maintaining the curved silhouette of the Lineal Collection, the upholstered comfort has added softness and comfort and is available in a wide range of textiles.

Junto con Lineal y Lineal Corporate, Lineal Comfort configura una de las colecciones de sillas, sillones, butacas y banquetas más extensa y polivalente. En este caso, la síntesis perfecta de Lineal, un trazo gráfico que parece suspendido en el aire, potencia su confort con una amplia gama de tapizados.

## Lineal Comfort

by Lievore Altherr Molina





**Training room**  
**Sala de reunión**  
▼ SO 0595

Stackable armchair. Upholstered seat and backrest. Steel sled base.  
Sillón apilable. Carcasa tapizada. Base de patín de varilla de acero.







◀ **SI 0606**  
 Chair. Upholstered seat and backrest. Four-legged solid beech wood base. Silla. Carcasa tapizada. Base de cuatro patas de madera maciza de haya.

◀ **SO 0607**  
 Armchair. Upholstered seat and backrest. Four-legged solid beech wood base. Sillón. Carcasa tapizada. Base de cuatro patas de madera maciza de haya.

**Workspace  
 Espacio de trabajo**

◀ **SI 0567**  
 Chair. Upholstered seat and backrest. Steel oval plate cantilever base. Silla. Carcasa tapizada. Base cantilever de pletina ovalada de acero.

**Cafeteria  
 Cafetería**

▼ **SI 0594**  
 Stackable chair. Upholstered seat and backrest. Steel sled base. Silla apilable. Carcasa tapizada. Base de patín de varilla de acero.







**Waiting area**  
**Zona de espera**  
◀ **BU 0596**

Stackable lounge chair. Upholstered seat and backrest. Steel sled base.  
Butaca con brazos y apilable.  
Carcasa tapizada, Base de patín de varilla de acero.

▶ **BU 0596**

**Waiting area**  
**Zona de espera**  
▼ **BU 0597**

Stackable lounge chair. Upholstered seat and backrest. Steel sled base.  
Butaca apilable. Carcasa tapizada.  
Base de patín de varilla de acero.







**Workspace**  
**Espacio de trabajo**

◀ **BQ 0609**

Counter stool. Upholstered seat and backrest. Four-legged solid beech wood base.  
Banqueta baja. Carcasa tapizada. Base de cuatro patas de madera maciza de haya.

**Educational**  
**Educativo**

▼ **BQ 0599**

Barstool. Upholstered seat and backrest. Steel sled base.  
Banqueta. Carcasa tapizada. Base de patín de varilla de acero.



As a result of the search for distinctiveness and specialization, Lineal grows in proportions with the Lineal Corporate. It is intended for work areas and public spaces that demand an upscale look and durability for increased usage.

Como resultado de la búsqueda de una mayor singularidad y especificidad, Lineal crece en proporciones y se especializa con Lineal Corporate. Está dirigida a ámbitos de trabajo y espacios públicos que demandan mayor representatividad y un uso continuado.

## Lineal Corporate

by Lievore Altherr Molina







**Workspace**  
**Espacio de trabajo**  
**◀ SI 0780**  
 Chair. Upholstered seat and backrest. Central aluminum swivel base with five casters. Height adjustable.  
 Silla. Carcasa tapizada. Base central de aluminio giratoria con cinco ruedas. Regulable en altura.

**Workspace**  
**Espacio de trabajo**  
**▼ SI 0553**  
 Chair. Upholstered seat and backrest. Cantilever base with steel oval plate cantilever base.  
 Silla. Carcasa tapizada. Base cantilever de pletina ovalada de acero.

**Workspace**  
**Espacio de trabajo**  
**► SO 0779**  
 Armchair. Upholstered seat and backrest. Central aluminum swivel base with return system.  
 Sillón. Carcasa tapizada. Base central de aluminio giratoria con sistema de retorno.

**► SO 0781**  
 Armchair. Upholstered seat and backrest. Central aluminum swivel base with five casters. Height adjustable.  
 Sillón. Carcasa tapizada. Base central de aluminio giratoria con cinco ruedas. Regulable en altura.







**Workspace**  
**Espacio de trabajo**  
**▲ SO 0554**

Armchair. Upholstered seat and backrest. Cantilever base with steel oval plate cantilever base.  
 Sillón. Carcasa tapizada. Base cantilever de pletina ovalada de acero.

**◀ BU 0783**  
 Lounge chair. Upholstered seat and backrest. Four star central aluminum swivel base with return-system. Matte black finish.  
 Butaca. Carcasa tapizada. Base central giratoria de aluminio de cuatro aspas con sistema de retorno. Acabado negro mate.

**Waiting area**  
**Zona de espera**  
**► BU 0782**  
 Lounge chair. Upholstered seat and backrest. Four star central aluminum swivel base with return-system.  
 Butaca. Carcasa tapizada. Base central giratoria de aluminio de cuatro aspas con sistema de retorno.





Impressive and resounding, Manfred is a selection of sofas intended for all types of applications such as workplace relaxation zones. Manfred conveys comfort and presents a unique perspective with respect to the classic language of great upholstered pieces.

Representativo y rotundo, Manfred es un programa de sofás combinables entre sí y adaptables a todo tipo de zonas de relax y espera en ámbitos de trabajo o contract. Manfred transmite confort y plantea una mirada singular con respecto al lenguaje clásico de las grandes piezas tapizadas.

# Manfred

by Lievore Altherr Molina





**Waiting area**  
**Zona de espera**

**▼ SF 2090**

One seater upholstered sofa.  
Sofá tapizado de una plaza.

Integrate with all existing products  
to create a complete and unified product  
concept with our products.

Reclina de 180°.  
Reclina de 180°.  
Reclina de 180°.  
Reclina de 180°.

Reclina de 180°.  
Reclina de 180°.  
Reclina de 180°.  
Reclina de 180°.





◀ SF 2096  
Two seater upholstered sofa  
with solid beech wood arms.  
Sofá tapizado de dos plazas  
con brazos de madera maciza  
de roble.

Restaurant  
Restaurante  
◀ SF 2091  
two seater upholstered  
sofa.  
Sofá tapizado de dos plazas.

Waiting area  
Zona de espera  
▼ SF 2092



Manfred

179



178

Manfred



A classic design that conveys serenity and grandeur. The Manila Collection which includes chairs, armchairs, lounges and stools is recognized for its timelessness and comfort. Manila has adapted over time and is installation in numerous architectural projects.

Manila es un clásico que transmite serenidad y nobleza, una colección que abarca sillas, sillones, butacas y banquetas caracterizadas por su atemporalidad y comodidad. Manila se ha adaptado en el tiempo y forma parte de numerosos proyectos arquitectónicos.

# Manila

by Lievore Altherr Molina









**Conference room**  
**Sala de reunión**  
**▼ SO 2017**

Armchair. Upholstered seat and backrest. Low back version.  
Sillón. Asiento y respaldo tapizado. Versión de respaldo bajo.







**Restaurant  
Restaurante**

▲ **SI 2020**

Chair. Upholstered seat and wicker backrest. Low back version.  
Silla. Asiento tapizado y respaldo de rejilla. Versión de respaldo bajo.

**Waiting area  
Zona de espera**

► **BU 2031**

Lounge chair. Upholstered seat and wicker backrest.  
Butaca. Asiento tapizado y respaldo de rejilla.

**Restaurant  
Restaurante**

► **SO 2033**

Stackable armchair. Upholstered seat and backrest. Low back version.  
Sillón apilable. Asiento y respaldo. Versión de respaldo bajo.







**Residential  
Hogar**

◀ **SO 2017**

Armchair. Upholstered seat and backrest. Low back version.  
Sillón. Asiento y respaldo tapizado.  
Versión de respaldo bajo.

▶ **SO 2061**

Armchair. Upholstered seat and backrest. Corporate version.  
Sillón. Asiento y respaldo tapizado.  
Versión Corporate.

**Workspace**

**Espacio de trabajo**

▼ **SO 2061**





Moody represents the finest quality of wood combined with upholstery. Its discreet and basic lines give it extraordinary versatility to be used in all types of architectural spaces. Moody can be as subtle as it is sophisticated in both the chair and barstool version.

Moody es la representación de la esencia de la madera en combinación con el tapizado. Sus líneas discretas y básicas le confieren una extraordinaria versatilidad, por ello se integra en todo tipo de espacios arquitectónicos.

# Moody

by Lievore Altherr Molina







◀ **SI 1260**  
Chair. Upholstered seat  
and backrest.  
Silla. Asiento y respaldo  
tapizado.

**Cafeteria**  
**Cafeteria**  
◀ **BQ 1261**  
Barstool. Upholstered  
seat and backrest.  
Banqueta. Asiento y  
respaldo tapizado.

**Residential**  
**Hogar**  
▼ **SI 1260**





Born from the woodworking process, Nub is an evocation of craftsmanship and a challenge for innovation. Ornamental and decorative, Nub breaks with all conventions and poses as an unexpected collage of various elements of the repertoire of chairs.

A partir de un elaborado trabajo de ebanistería, Nub es una evocación del trabajo artesano y una invitación al atrevimiento. Ornamental y decorativa, Nub rompe convenciones y se presenta como un collage inesperado de distintos elementos del repertorio de sillas.

# Nub

by Patricia Urquiola







◀ **SI 1451**  
 Chair. Upholstered seat cushion.  
 Central polished aluminum swivel base  
 with return system.  
 Silla. Cojín tapizado en asiento y base  
 central giratoria de aluminio pulido, con  
 sistema de retorno.

◀ **SI 1449**  
 Chair. Upholstered seat cushion. Four-  
 legged solid beech wood base.  
 Silla. Cojín tapizado en asiento. Base  
 de cuatro patas de madera maciza de  
 haya.

◀ **SI 1450**  
 Chair. Upholstered seat cushion. Steel  
 sled base.  
 Silla. Cojín tapizado en asiento. Base de  
 patín de acero.

◀ **SI 1451**  
**Restaurant**  
**Restaurante**  
 ▶ **SO 1434**  
 Armchair. Upholstered seat cushion.  
 Four-legged solid beech wood base.  
 Sillón. Cojín tapizado en asiento. Base  
 de cuatro patas de madera maciza de  
 haya.

**Cafeteria**  
**Cafetería**  
 ▼ **SO 1434**







◀ **SI 1449**  
Chair. Upholstered seat cushion. Four-legged solid beech wood base.  
Silla. Cojín tapizado en asiento. Base de cuatro patas de madera maciza de haya.

**Restaurant  
Restaurante**

▼ **SI 1451**  
Chair. Upholstered seat cushion. Central polished aluminum swivel base with return system.  
Silla. Cojín tapizado en asiento y base central giratoria de aluminio pulido, con sistema de retorno.

**Restaurante  
Restaurant**

▶ **SO 1435**  
Armchair. Upholstered seat cushion. Steel sled base.  
Sillón. Cojín tapizado en asiento. Base de patín de acero.





**Cafeteria**  
**Cafetería**  
▼ **BC 1441**

Bench. Upholstered seat cushion.  
Four-legged solid beech wood  
base.

Bancada. Cojín tapizado en  
asiento. Base de cuatro patas de  
madera maciza de haya.

▼ **SO 1434**

Armchair. Upholstered seat  
cushion. Four-legged solid beech  
wood base.

Sillón. Cojín tapizado en asiento.  
Base de cuatro patas de madera  
maciza de haya.







◀ **BU 1445**

Lounge chair. Upholstered seat cushion.  
Central aluminum swivel base.  
Butaca. Cojín tapizado en asiento. Base central giratoria de aluminio con sistema de retorno.

◀ **BU 1445**

◀ **BC 1441**

Bench. Upholstered seat cushion.  
Four-legged solid beech wood base.  
Bancada. Cojín tapizado en asiento. Base de cuatro patas de madera maciza de haya.

**Cafeteria**

**Cafeteria**

▼ **BU 1437**

Lounge chair. Upholstered seat cushion.  
Four-legged solid beech wood base.  
Butaca. Cojín tapizado en asiento. Base de cuatro patas de madera maciza de haya.





► **SO 1454**

Armchair. Steel rod and solid beech wood rocker base. Removable upholstered seat cushion.  
Butaca. Base de balancín de varilla de acero y madera maciza de haya. Cojín tapizado en asiento.

▼ **BQ 1452**

Barstool. Four-legged solid beech wood base.  
Banqueta. Base de 4 patas de madera maciza de haya.

▼ **BQ 1453**

Barstool. Four-legged solid beech wood base.  
Banqueta. Base de 4 patas de madera maciza de haya.

**Waiting area**

**Zona de espera**

► **BU 1455**

Counter stool with solid beech seat and back, upholstered seat pad and four-legged solid beech wood base.  
Banqueta baja con asiento y respaldo de madera maciza de haya, cojín tapizado en asiento y base de 4 patas de madera maciza de haya.

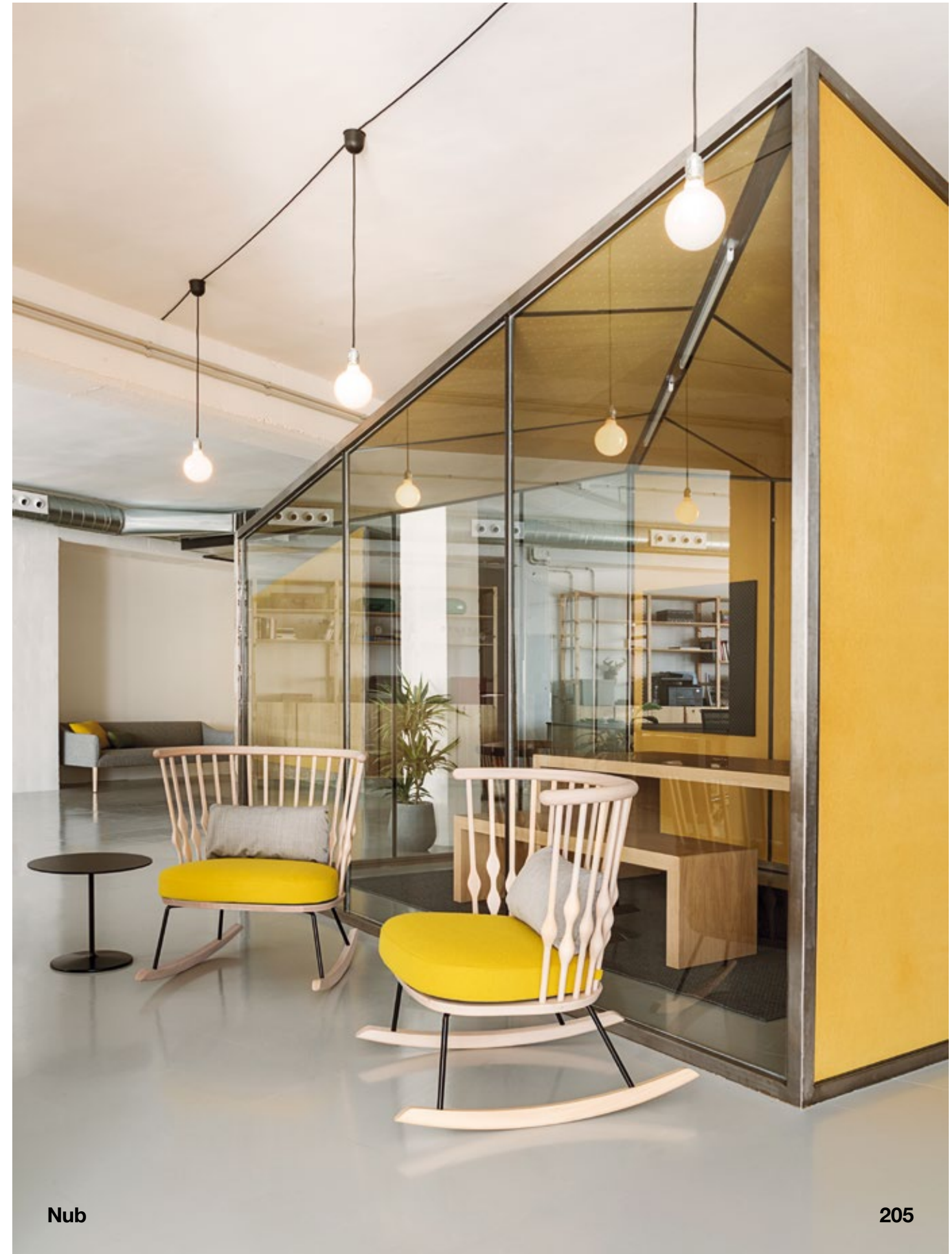



Enveloping, suggestive, warm and at the same time technological; Nuez Chair is born from the idea of creating a modulating seat as if it were a sheet of paper. Nuez Chair's shell –made from injected thermo-polymer– is expressed as a flexible surface that embraces the body when seated and whose shape presents the same folds in the corners as a folded sheet of paper, conveying softness and materiality.

Envolvente, sugestiva, cálida y a la vez tecnológica; Nuez Chair nace de la idea de crear un asiento modulándolo como si fuera una hoja de papel. La carcasa de Nuez Chair – realizada a partir de termopolímero inyectado – se expresa como una superficie flexible que abraza al sentarse y cuya forma presenta los mismos pliegues en las esquinas que una gran hoja de papel cerrada, transmitiendo suavidad y materialidad.

## Nuez

by Patricia Urquiola





► **SO 2770**

Armchair with thermo-polymer seat and backrest. Seat and backrest fixed cushion. Four-legged solid oak wood base.  
Sillón con carcasa de termopolímero. Cojín fijo de asiento y respaldo. Base de cuatro patas de madera maciza de roble.

**Residential  
Hogar**

▼ **SO 2771**

Armchair with thermo-polymer seat and backrest. Seat and backrest fixed cushion. Steel cantilever base finished in black.  
Sillón con carcasa de termopolímero. Cojín fijo de asiento y respaldo. Base cantiléver de acero en acabado negro.

**Restaurant  
Restaurante**

► **SO 2770**





**Residential  
Hogar**

**▼ SO 2771**

Armchair with thermo-  
polymer seat and backrest.  
Seat and backrest fixed  
cushion. Steel cantilever  
base finished in black.  
Sillón con carcasa de  
termopolímero. Cojín fijo  
de asiento y respaldo.  
Base cantiléver de acero  
en acabado negro.





▼ **SO 2772**

Armchair with thermo-polymer seat and backrest. Seat fixed cushion. Swivel four-star base with self-return and finished in white.

Silón con carcasa de termopolímero. Cojín fijo de asiento. Base central giratoria de cuatro aspas con sistema de retorno en acabado blanco.

▼ **SO 2773**

Armchair with thermo-polymer seat and backrest. Seat fixed cushion. Height adjustable central swivel base with five casters and self-return finished in white.

Silón con carcasa de termopolímero. Cojín fijo de asiento. Base de cinco ruedas regulable en altura en acabado blanco.

**Home office**

► **SO 2773**



212



Nuez



Nuez

213



**Workspace**  
**Zona de trabajo**  
**▼ SO 2773**

Armchair with thermo-polymer seat and backrest. Seat fixed cushion. Height adjustable central swivel base with five casters and self-return finished in black.  
Sillón con carcasa de termopolímero. Cojín fijo de asiento. Base de cinco ruedas regulable en altura en acabado negro.





The Pillow is a synonym for comfort. Available in various versions of chair, armchair and lounge chair. Pillow always maintains defined and harmonious proportions, and good balance between its resilient frame and the warmth of its upholstery. It adapts to difference types of public and residential projects and spaces.

Pillow es sinónimo de comodidad. Disponible en distintas medidas de silla, sillón y butaca, Pillow mantiene siempre unas proporciones contenidas y armónicas, y un buen equilibrio entre la resistencia de su estructura de madera maciza y la calidez del tapizado.

# Pillow

by Lievore Altherr Molina





**Workspace**  
**Espacio de trabajo**  
**▼ SO 1541**

Armchair. Upholstered arms, seat and back.  
Sillón. Asiento, brazos y respaldo tapizado.







**Workspace**  
**Espacio de trabajo**

◀ **SO 1541**

Armchair. Upholstered arms, seat and back.  
Sillón. Asiento, brazos y respaldo tapizado.

▶ **SI 1540**

Chair. Upholstered seat and back.  
Silla. Asiento y respaldo tapizado.

▼ **SI 1540**

▼ **SO 1541**





New communal spaces demand sofas and lounge chairs that are comfortable, adaptable and capable of reconfiguration. The Raglan answers to these prerequisites by providing lightweight and resilient design available in 1, 2, or 3 seats. Its perimeter edging provides uniqueness and character.

Los nuevos entornos colectivos reclaman sofás y butacas (se ofrece en 1, 2 y 3 plazas) como Raglan, confortables y adaptables, capaces de configurar áreas de encuentro y descanso. Raglan es ligero, resistente y muy versátil, su ribete perimetral lo singulariza y le aporta carácter.

# Raglan

by Piergiorgio Cazzaniga





**Waiting area**  
**Zona de espera**

▼ **SF 2073**

Three-seater corner sofa with upholstered seat and back. Four-legged aluminum base in matte black. Right side.

Sofá rinconero de tres plazas con asiento y respaldo tapizado. Base de cuatro patas de aluminio acabado en negro mate. Lado derecho.

▼ **SF 2067**

Three-seater sofa with upholstered seat and back. Four-legged aluminum base in matte black.  
Sofá de tres plazas con asiento y respaldo tapizado. Base de cuatro patas de aluminio acabado en negro mate.

**Waiting area**  
**Zona de espera**

▼ **SF 2072**

Three-seater corner sofa with upholstered seat and back. Four-legged aluminum base in matte black. Left side.

Sofá rinconero de tres plazas con asiento y respaldo tapizado. Base de cuatro patas de aluminio acabado en negro mate. Lado izquierdo.

▼ **SF 2067**

Three-seater sofa with upholstered seat and back. Four-legged aluminum base in matte black.  
Sofá de tres plazas con asiento y respaldo tapizado. Base de cuatro patas de aluminio acabado en negro mate.







**Waiting area  
Zona de espera**

**◀ SF 2066**

Upholstered two-seater sofa.  
Sofá de dos plazas tapizado.

**◀ ME 8525 / ME 8627**

**◀ SF 2067**

Upholstered three-seater sofa.  
Sofá de tres plazas tapizado.

**Waiting area  
Zona de espera**

**▼ BU 2065**

Upholstered lounge chair.  
Butaca tapizada.





**Waiting area**  
**Zona de espera**  
▶ SF 2067  
Upholstered three-seater sofa.  
Sofá de tres plazas tapizado.

**Residential**  
**Hogar**  
▼ BU 2065  
Upholstered lounge chair.  
Butaca tapizada.  
▼ SF 2066  
Upholstered two-seater sofa.  
Sofá de dos plazas tapizado.

**Waiting area**  
**Zona de espera**  
▶ SF 2067  
▶ SF 2066  
▶ ME 8622





▼ **BC 2074**

One-seater bench with four-legged aluminum injected base in black.

Bancada de una plaza con asiento tapizado y base de cuatro patas de inyección de aluminio y acabado negro.

▼ **BC 2076**

Three-seater bench with four-legged aluminum injected base in black.

Bancada de tres plazas con asiento tapizado y base de cuatro patas de inyección de aluminio y acabado negro.

▼ **BC 2077**

Two-seater bench with four-legged aluminum injected base in black.

Bancada de dos plazas con asiento tapizado y base de cuatro patas de inyección de aluminio y acabado negro.

**Waiting area**  
**Zona de espera**

▼ **BC 2076**



**Waiting area**

**Zona de espera**

▼ **BC 2076**

Three-seater bench with four-legged aluminum injected base in black.

Bancada de tres plazas con asiento tapizado y base de cuatro patas de inyección de aluminio y acabado negro.





Radical and graphic, made entirely with solid oak wood, RDL is constructed entirely from solid oak and is the paradigm of a highly refined chair. Although it may appear extreme in appearance, the truth is that RDL conveys the serenity and calmness of timeless designs.

Radical y gráfica, completamente realizada en madera maciza de roble, RDL es el arquetipo del concepto universal de silla depurado al máximo. Aunque en apariencia pueda parecer extrema, lo cierto es que RDL transmite la serenidad y la tranquilidad de los diseños atemporales.

# RDL

by Lievore Altherr Molina





► **SO 7292**

Armchair. Oak board seat and backrest.  
Sillón. Asiento y respaldo de tablero de roble.

▼ **BQ 7297**

Backless barstool with oak board seat and solid oak wood frame.  
Banqueta sin respaldo con asiento de tablero de roble y estructura de madera maciza de roble.

▼ **BQ 7297**

Barstool with oak board seat and solid oak wood frame.  
Banqueta alta con asiento de tablero de roble y estructura de madera maciza de roble.

**Residential**

**Hogar**

► **SI 7291**

Chair. Oak board seat and backrest.  
Silla. Asiento y respaldo de tablero de roble.

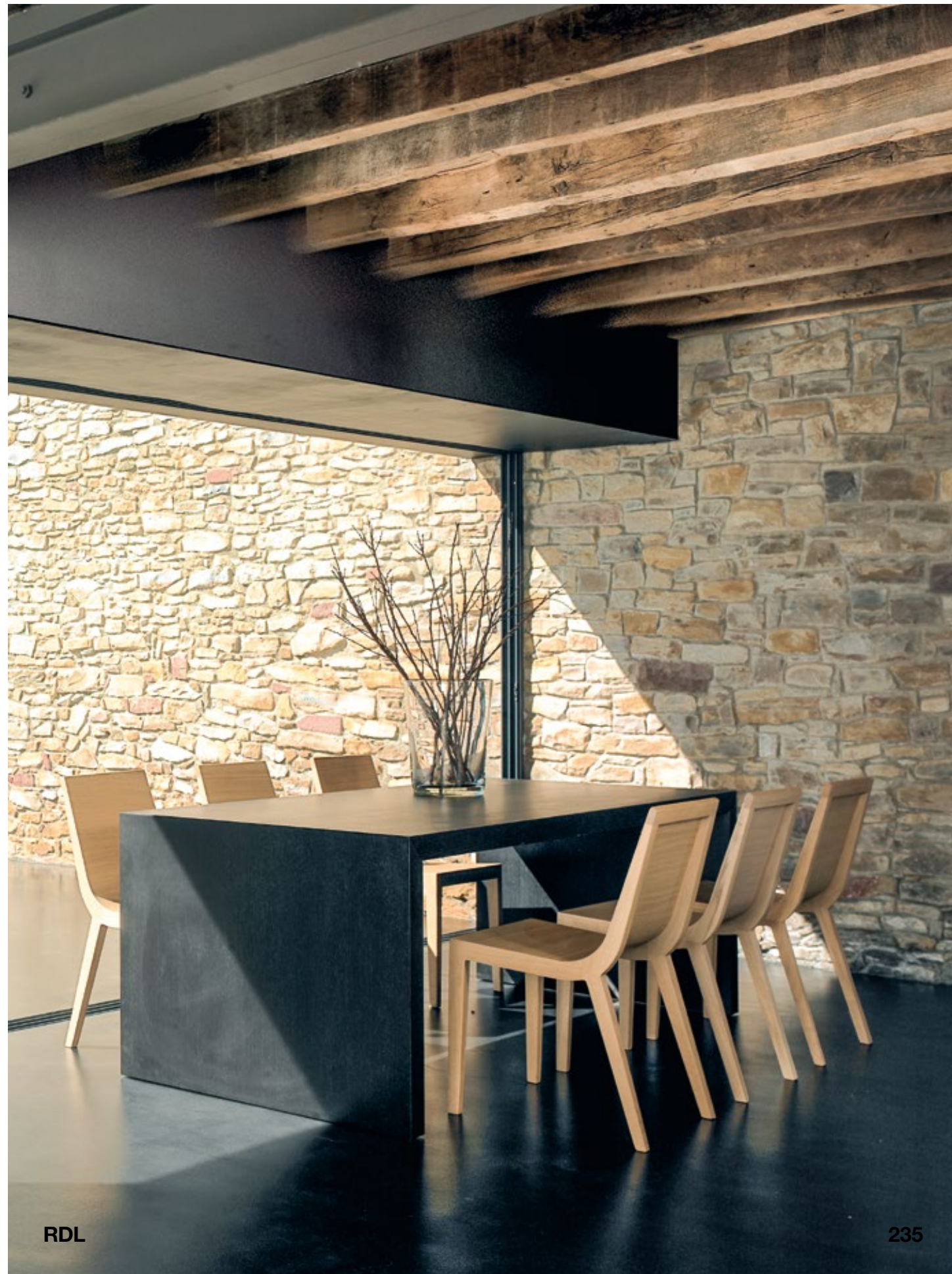



**Trienal**  
**Waiting area**  
**Zona de espera**  
**▼ BC 7004**

Three seater bench with oak board  
seat and backrest  
Banco de tres plazas. Asiento y  
respaldo de tablero de roble.

ORAN  
LINE





Ronda is an iconic chair that has best expressed our constant quest for technical and aesthetic innovation, versatility and quality. It was developed in a wide range of options that make it suitable for all types of projects and aesthetic proposals.

Ronda es un asiento icónico, uno de los que mejor han sabido expresar nuestra búsqueda constante de innovaciones técnicas y estéticas, de versatilidad y calidad. Se ha desarrollado en una extensa gama de opciones, idóneas para todo tipo de proyectos y propuestas estéticas.

# Ronda

by Lievore Altherr Molina





► **SO 0461**

Swivel central base with solid ash wood legs. Oak board seat and back.  
Base central giratoria de cuatro aspas de madera maciza de fresno. Carcasa de tablero de roble.

**Conference room**

**Sala de reunión**

▼ **SO 0461**

**Restaurant**

**Restaurante**

► **SO 0459**

Base with four legs in oak board. Oak board seat and back.

Base de cuatro patas de tablero de roble. Carcasa de tablero de roble.







▲ **SO 0453**  
Steel sled base. Upholstered seat and back.  
Base de patín de varilla de acero.  
Carcasa tapizada.

▲ **SO 0465**  
Four star central aluminum swivel base with return system. Upholstered seat and back.  
Base central giratoria de aluminio de cuatro aspas con sistema de retorno. Carcasa tapizada.

► **BQ 0476**  
Barstool. Four-legged steel swivel base with polished chrome finish. Upholstered seat and back.  
Banqueta. Base giratoria de cuatro patas de acero y acabado cromo brillo.

**Conference room**  
**Sala de reunión**  
► **SO 0465**



Ronda



Ronda



In Sail, Sail Wood and Sail Leather the technology in manufacturing reaches its highest quality to achieve a lightweight and solid chair that is both comfortable and functional. Sail arises from the desire to create a paradigmatic chair, a perfect combination of versatility, strength and elegance from a comprehensive study of the materials.

En Sail, Sail Wood y Sail Leather la tecnología alcanza su máxima expresión para obtener una silla muy ligera y sólida, tan cómoda como esencial. Sail nace de la voluntad de crear una silla paradigmática, una suma perfecta de polivalencia, fuerza y elegancia a partir de un estudio exhaustivo del material.

# Sail

by Piergiorgio and Michele Cazzaniga





**Workspace**  
**Espacio de trabajo**  
▼ SI 1245

Stackable chair in thermopolymer. Suitable for outdoor use.  
Silla apilable de termopolímero. Válido para uso en exterior.

► SI 1245

**Cafeteria**  
**Cafetería**  
► SI 1245







◀ **SI 1248**  
Stackable chair with oak board.  
Silla apilable de tablero de roble.

**Cafeteria**  
**Cafetería**  
▼ **SI 1248**

**Cafeteria**  
**Cafetería**  
▶ **SI 1245**  
Stackable chair in thermo-polymer.  
Suitable for outdoor use.  
Silla apilable de termopolímero.  
Válido para uso en exterior.



248

Sail



Sail

249



▼ **SI 1246**  
Chair fully upholstered  
in cuero leather.  
Silla tapizada en cuero.

**Residential**  
**Hogar**  
► **SI 1246**





Serena has undergone an extensive redesign without losing its essence and original characteristics: elegance, unique design, ease and contemporary aesthetics. This collection now features optional upholstered finish that increases its comfort and applicability in all types of interior spaces.

Serena ha experimentado un profundo rediseño si perder su esencia y sus características originales: elegancia, diseño singular, naturalidad y estética contemporánea. Esta colección incorpora la opción de acabado tapizado que incrementa su confort y la representatividad en todo tipo de ambientes de interior.

## Serena

by Lievore Altherr Molina





**Restaurant  
Restaurante**

▼ SO 1346

Armchair. Upholstered seat and back and solid oak wood frame.  
Sillón. Asiento y respaldo tapizado. Estructura de madera maciza de roble.







◀ **SI 1344**  
Chair. Upholstered seat and back and solid oak wood frame.  
Silla. Asiento y respaldo tapizado. Estructura de madera maciza de roble.

**Educational  
Educativo**  
▼ **BU 1348**

Low back lounge chair. Upholstered seat and back and solid oak wood frame.  
Butaca de respaldo bajo. Asiento y respaldo tapizado. Estructura de madera maciza de roble.

**Waiting area  
Zona de espera**  
▶ **BU 1350**

Low back lounge chair with arms. Upholstered seat and back and solid oak wood frame.  
Butaca de respaldo bajo con brazos. Asiento y respaldo tapizado. Estructura de madera maciza de roble.





In addition to being comfortable and balanced, Siesta is a modular sofa that is extremely versatile, resilient and easy to maintain. Its great comfort, beautiful proportions and great functionality make it suitable for a variety of configurations that adapt to all needs and spaces.

Además de confortable y equilibrado, Siesta es un sofá modular extraordinariamente versátil, resistente y fácil de mantener. Su gran confort, bellas proporciones, y gran funcionalidad lo adecuan para las más variadas composiciones adaptadas a cualquier requerimiento y espacio.

# Siesta

by Lievore Altherr Molina





**Waiting area**  
**Zona de espera**

▼ **SF 3006**

One seater upholstered corner sofa (right side).  
Sofá tapizado rinconero de una plaza (lado derecho).

▼ **3x SF 3005**

One seater upholstered sofa.  
Sofá tapizado de una plaza.

▼ **SF 3007**

One seater upholstered corner sofa (left side).  
Sofá tapizado rinconero de una plaza (lado izquierdo).

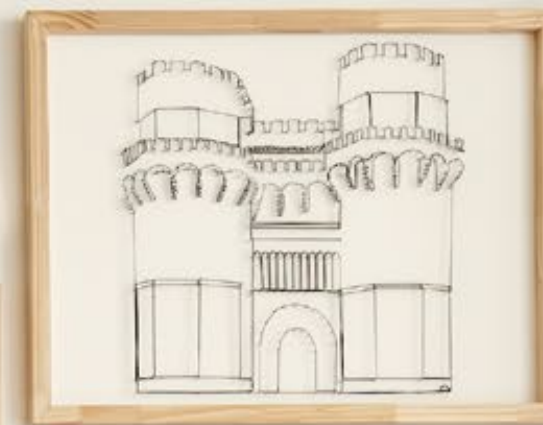
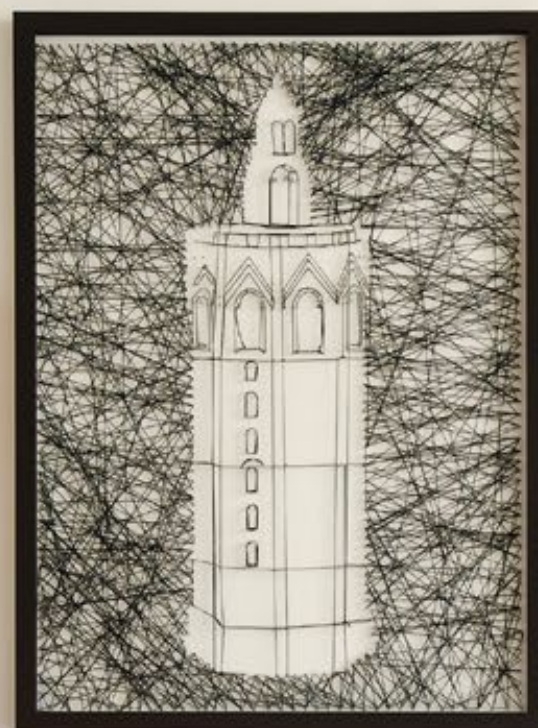
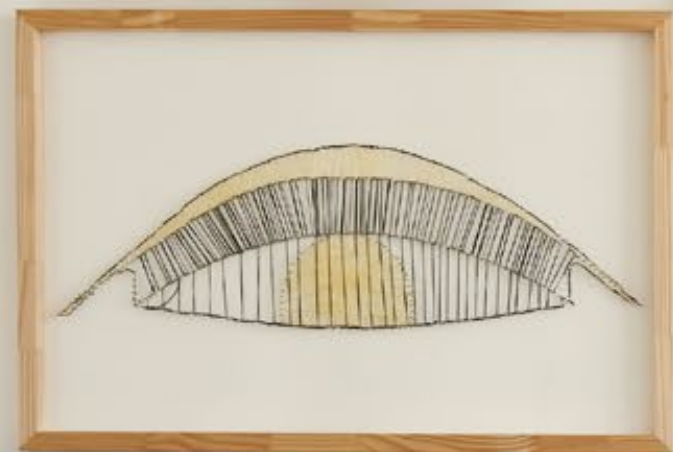





**Residencial  
Hogar**

▲ **SF 3006**  
One seater upholstered corner sofa (right side).  
Sofá tapizado rinconero de una plaza (lado derecho).

▲ **SF 3005**  
One seater upholstered sofa.  
Sofá tapizado de una plaza.

▲ **SF 3007**  
One seater upholstered corner sofa (left side).  
Sofá tapizado rinconero de una plaza (lado izquierdo).

▶ **SF 3006**

▶ 3x **SF 3005**

▶ **SF 3007**

▶ **SF 3005**

▶ **RS 3009**

Upholstered ottoman.  
Reposapiés tapizado.

▶ **SF 3005**

▶ **RS 3009**





Sit is a basic idea developed with many possibilities in both materiality and use such as gathering spaces and other contract applications. Sit in all its versions adapts without losing any lightness or personality. It features a wide range of accessories to create rows or with writing surfaces.

Sit es una idea esencial desarrollada en todas sus posibilidades, tanto materiales como de uso, dedicada a instalaciones, colectividades y espacios de contract. En sus distintas versiones, Sit cuenta con una amplia gama de accesorios para formar filas o habilitar sistemas de escritura.

# Sit

by Lievore Altherr Molina





**Workspace**

**Espacio de trabajo**

**▼ SI 1200**

Stackable chair. Thermo-polymer seat and backrest. 4-legged tubular steel base.

Silla apilable. Asiento y respaldo de termopolímero. Base de 4 patas de tubo de acero.





**Workspace**

**Espacio de trabajo**

► **SI 1200 + DR 0802**

Chair. Thermo-polymer seat and backrest. Four-legged tubular steel base. Right desk accessory with panic latch rotation. Silla. Asiento y respaldo de termopolímero. Base de cuatro patas de tubo de acero. Pala de escritura derecha con rotación antipánico.

**Conference room**

**Sala de reunión**

▼ **SI 1201**

Stackable chair. Thermo-polymer seat and backrest. Steel sled base. Silla apilable. Asiento y respaldo de termopolímero. Base de patín de varilla de acero.

**Cafeteria**

**Cafetería**

► **BQ 1209**

Stackable barstool. Oak board seat and backrest. Banqueta apilable. Asiento y respaldo de tablero de roble.

► **BQ 1204**

Stackable counter stool. Thermo-polymer seat and backrest. Banqueta baja apilable. Asiento y respaldo de termopolímero.

► 2x **BQ 1203**

Stackable barstool. Thermo-polymer seat and backrest. Banqueta alta apilable. Asiento y respaldo de termopolímero.

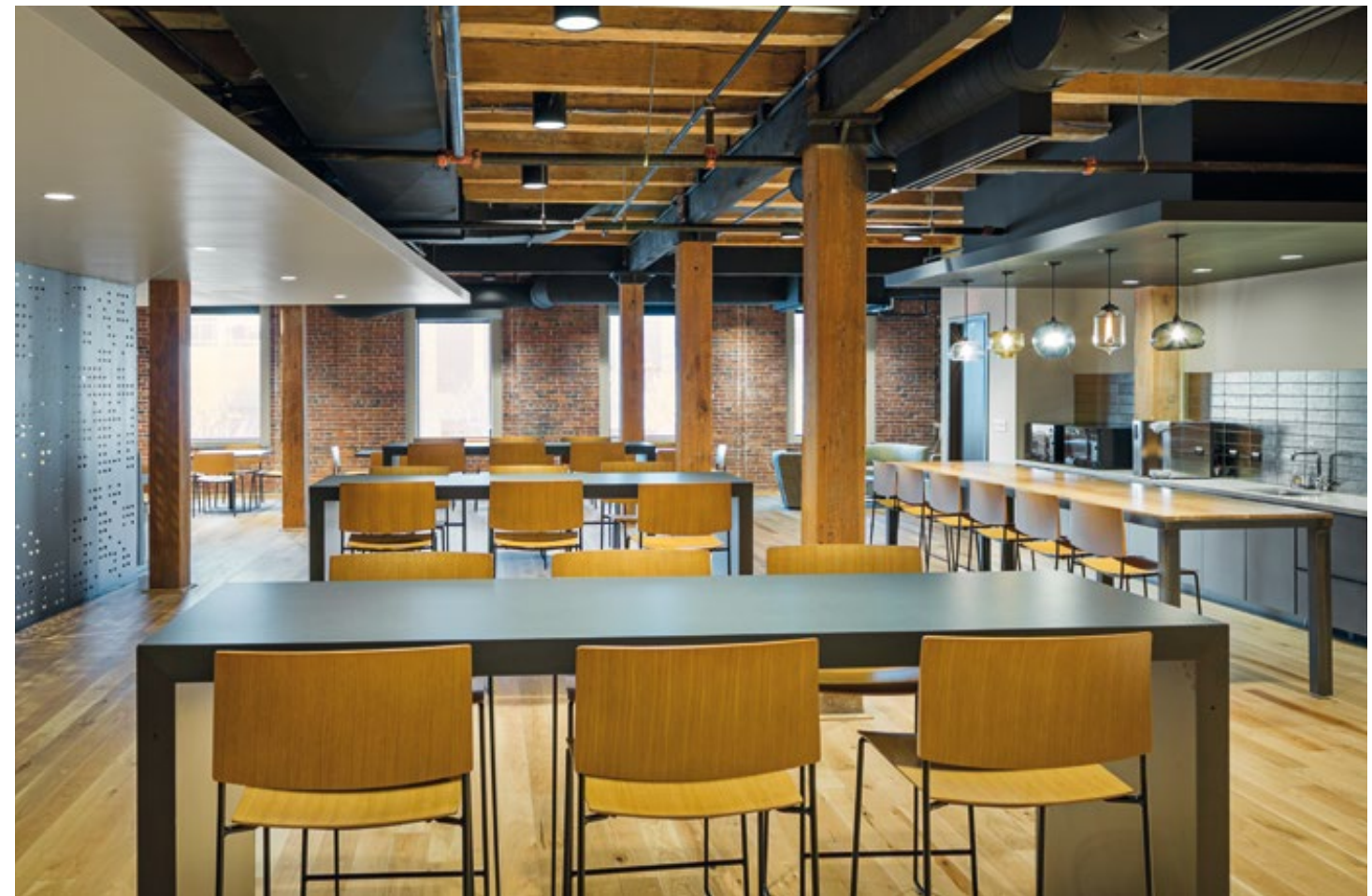





**Educational  
Educativo**

◀ **SI 1200**

Stackable chair. Thermo-polymer seat and backrest. Four-legged steel base. Titanium finish.  
Silla apilable. Asiento y respaldo de termopolímero. Base de cuatro patas de acero. Acabado titanio.

◀ **SI 1201**

Stackable chair. Thermo-polymer seat and backrest. Steel sled base. Bright chrome finish.  
Silla apilable. Asiento y respaldo de termopolímero. Base de patín de acero. Acabado cromo brillo.

**Waiting area  
Zona de espera**

◀ **SI 1212**

Stackable chair. Upholstered seat and backrest. Four-legged tubular steel base.  
Silla apilable. Asiento y respaldo tapizado. Base de cuatro patas de tubo de acero.

**Educational  
Educativo**

▼ **SI 1200**







**Outdoor**

◀ **SI 1235**

Stackable chair. Thermo-polymer seat and backrest. Four-legged tubular EPL-5 steel base.  
Silla apilable. Asiento y respaldo de termopolímero. Base de cuatro patas de tubo de acero EPL-5.

**Restaurant**

▼ **SI 1207**

Stackable chair with oak board seat and backrest. Steel sled base.  
Silla apilable. Asiento y respaldo de tablero de roble. Base de patín de varilla de acero.



Smart combines the natural characteristics of solid beech wood with fine ergonomics resulting in lightness, stackability and structural durability. It's a perfect chair both for public and private spaces and now with a webbed seat that makes it even more comfortable.

Smart combina la naturalidad de la madera maciza de haya con una cuidada ergonomía para lograr ligereza, apilabilidad y resistencia estructural. Es una silla perfecta tanto para espacios públicos como privados.

# Smart

by Estudio Andreu





► SI 0610  
Oak board seat.  
Asiento de tablero de roble.  
► SI 0610

Restaurant  
Restaurante  
▼ SI 0610

Cafeteria  
Cafetería  
► SI 0610

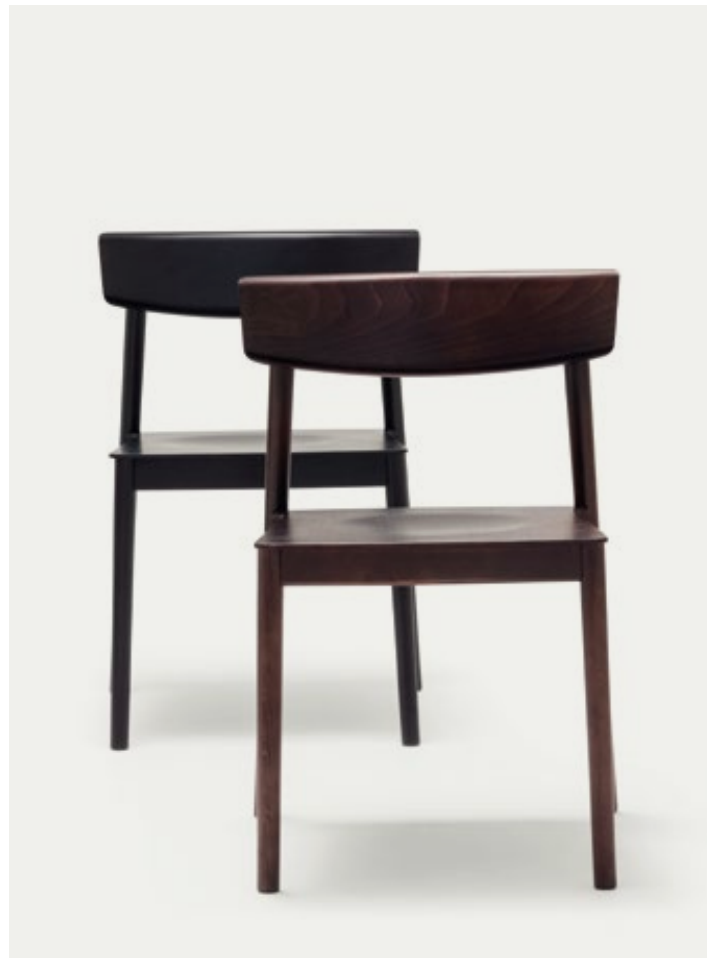

276

Smart



Smart

277





278

Smart

**Workspace**  
**Espacio de trabajo**

◀ **SI 0614**

Seat webbing in cream color.  
Asiento cinchado en color crema.

**Cafeteria**  
**Cafetería**

▶ **SI 0611**

Upholstered seat.  
Asiento tapizado.

▼ **SI 0610**

Oak board seat.  
Asiento de tablero de roble.

▼ **SI 0611**



Smart



279



► **BQ 0637**

Barstool with frame and back made of solid beech wood and oak board seat.

Banqueta alta con estructura y respaldo en madera maciza de haya. Asiento de tablero de roble.

▼ **BQ 0651**

Counter stool with frame and back made of solid beech wood. Oak board seat.

Banqueta baja con estructura y respaldo en madera maciza de haya y asiento de tablero de roble.

▼ **BQ 0637**

**Restaurant**  
**Restaurante**

► **BQ 0637**



280

Smart



Smart

281



Japanese and Scandinavian elements are brought together to create the Smile Collection. The design proves lightness can be dynamic. Force is obtained from the precise form and fluid structure, locked in a manner that makes this chair very resistant and durable.

Reúne de una manera natural rasgos japoneses y escandinavos. Smile demuestra cómo lo ligero puede ser dinámico; la fuerza se logra a partir del gesto preciso y fluido de su estructura, trabada de tal manera que convierten a esta silla en una pieza resistente y de gran durabilidad.

# Smile

by Lievore Altherr Molina







**Residential  
Hogar**

**▲ SO 0336**

Armchair. Upholstered seat and oak board backrest.  
Sillón. Asiento tapizado y respaldo de tablero de roble.

**◀ SO 0335**

Armchair. Oak board seat and backrest.  
Sillón. Asiento y respaldo de tablero de roble.

**Workspace**

**Espacio de trabajo**

**▶ SO 0335**



284

Smile



Smile

285





**Cafeteria**

**Cafeteria**

◀ **SI 0325**

Chair. Oak board seat and backrest.

Silla. Asiento y respaldo de tablero de roble.

◀ **BQ 0337**

Barstool. Oak board seat and backrest.

Banqueta. Asiento y respaldo de tablero de roble.

▶ **SI 0326**

Chair. Upholstered seat and oak board backrest.

Silla. Asiento tapizado y respaldo de tablero de roble.

**Restaurant**

**Restaurante**

▼ **SI 0324**

Chair. Upholstered seat and spindle backrest.

Silla. Asiento tapizado y respaldo de varillas.

▼ **SO 0334**

Armchair. Upholstered seat and spindle backrest.

Sillón. Asiento tapizado y respaldo de varillas.







**Restaurant  
Restaurante**

◀ SI 0323

Chair. Oak board seat and spindle backrest.  
Silla. Asiento tablero de roble y respaldo de varillas.

**Residential  
Hogar**

▲ SI 0323

**Residential  
Hogar**

▶ SI 0323





► BQ 0329

Backless barstool with oak board seat.  
Banqueta sin respaldo. Asiento de tablero de roble.

**Cafetería**

**Cafetería**

▼ BQ 0337

Barstool. Oak board seat and backrest.  
Banqueta. Asiento y respaldo de tablero de roble.

**Cafetería**

**Cafetería**

► BQ 0327

Barstool. Oak board seat and spindle backrest.  
Banqueta. Asiento tablero de roble y respaldo de varillas.

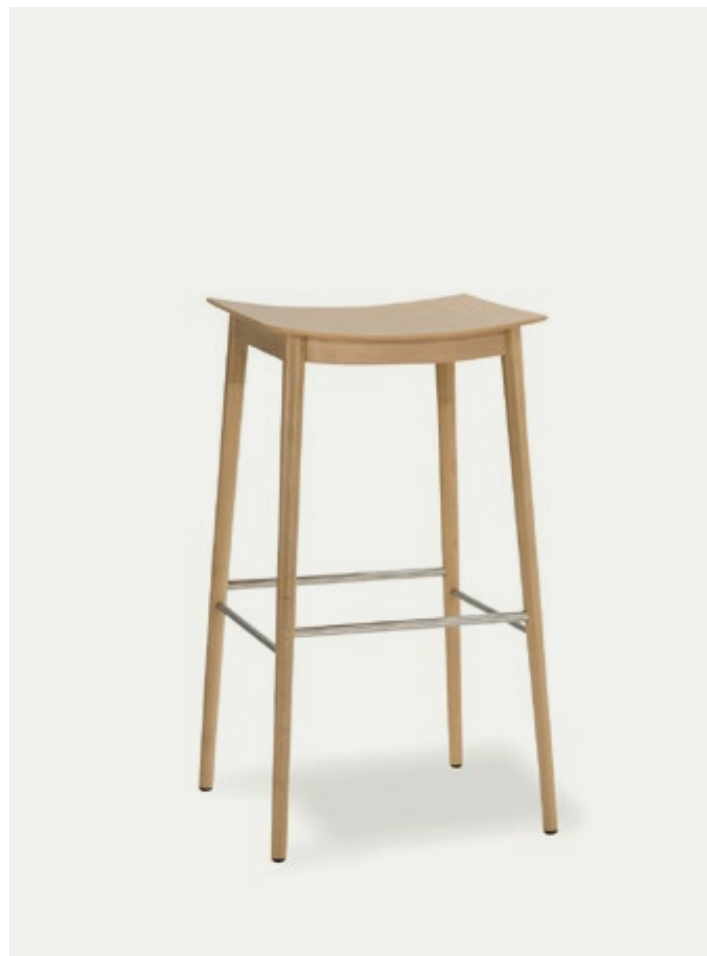



This family of chairs, armchairs and barstools are defined by the embracing shape of the backrest and for its balanced proportions. Tauro constructed injected polyurethane, a technique that guarantees great comfort and resistance for areas of high usage.

Esta familia de sillones, butacas y banquetas se define por el gesto envolvente de su respaldo y por sus proporciones equilibradas. Tauro está realizada a partir de poliuretano inyectado, una técnica que garantiza altas prestaciones de confort y resistencia.

# Tauro

by Lievore Altherr Molina





**Workspace  
Espacio de trabajo**

**▼ SO 4205**

Upholstered armchair. Four-legged solid beech wood base.

Sillón tapizado. Base de cuatro patas de madera maciza de haya.

**Waiting area  
Zona de espera**

**► BU 4206**

Upholstered lounge chair. Four-legged solid beech wood base.

Butaca tapizada. Base de cuatro patas de madera maciza de haya.







**Workspace**  
**Espacio de trabajo**  
◀ SO 4200  
Armchair. Upholstered seat and backrest.  
Sillón. Asiento y respaldo tapizado.

◀ SO 4200

**Restaurant**  
**Restaurante**  
◀ SO 4200

**Conference room**  
**Sala de reunión**  
▼ SO 4200







298

Tauro

**Waiting area  
Zona de espera**

**◀ BU 4201**

Lounge chair. Upholstered seat and backrest.  
Butaca. Asiento y respaldo tapizado.

**▼ BQ 4202**

Barstool. Upholstered seat and backrest.  
Banqueta. Asiento y respaldo tapizado.



Tauro

299



The design stands out for the durability and solidity that the solid oak wood provides and the exquisite webbing. A subtle combination traditional and modernity styling, the Valeria always expresses warmth and serenity.

Destaca por la resistencia y la solidez que le proporciona la madera maciza de roble y por el exquisito trabajo de cinchado, una sutil combinación entre tradición y modernidad. Sus múltiples versiones transmiten siempre calidez y serenidad.

## Valeria

by Estudio Andreu





► **SO 7508**

Armchair. Upholstered seat and webbing backrest.  
Sillón. Asiento tapizado y respaldo cinchado.

**Cafetería**

**Cafetería**

▼ **SI 7505**

Chair. Webbing seat and backrest.  
Silla. Asiento y respaldo cinchado.

**Residencial**

**Hogar**

► **SI 7505**

Chair. Webbing seat and backrest.  
Silla. Asiento y respaldo cinchado.





**Valeria Comfort  
Restaurant  
Restaurante**

▼ **SO 7520**  
Armchair. Upholstered seat and  
backrest.  
Sillón. Asiento y respaldo  
tapizado.

**Cafeteria  
Cafeteria**

► **BQ 7515**  
Barstool. Upholstered seat and  
webbing backrest.  
Banqueta alta. Asiento tapizado  
y respaldo cinchado.





Its uniqueness lies in the shape of its oval backrest and its refined design. Made of solid beech wood that provides great structural strength, the Zarina is available as a chair, armchair, stool and lounge chair.

El gesto de su respaldo ovalado y su diseño estilizado la convierten en inconfundible. Está disponible como silla, sillón, taburete y butaca, siempre realizada en madera de haya maciza que le otorga una gran resistencia estructural.

## Zarina

by William Sawaya





**Restaurant**  
**Restaurante**  
▼ SI 1708

Chair. Upholstered seat  
and backrest.  
Silla. Respaldo y asiento  
tapizado.





► **SI 1725**

Chair. Capitone upholstered seat and backrest.  
Silla. Asiento y respaldo tapizado estilo capitoné.

▼ **BQ 1728**

Barstool. Capitone upholstered seat and backrest.  
Banqueta alta. Asiento y respaldo tapizado estilo capitoné.

▼ **BU 1727**

Lounge chair. Capitone upholstered seat and backrest.  
Butaca. Asiento y respaldo tapizado estilo capitoné.

**Residencial  
Hogar**

► **SO 1710**

Armchair. Open backrest.  
Sillón. Respaldo abierto.



310



Zarina



Zarina

311



This table system stands out for its balanced proportions and technological detailing. It combines exquisite wood treatments with a built-in connection system (electrical and multimedia) to guarantee functionality.

Este programa de mesas destaca por sus proporciones equilibradas y sus detalles tecnológicos. Combina un tratamiento exquisito de la madera con un sistema integrado de conexiones –eléctricas y multimedia– que garantiza su funcionalidad además de su representatividad.

# Closed

by Estudio Andreu





**Workspace**  
**Espacio de trabajo**

▼ ME 6137

Bar height table with solid oak wood top and legs.  
Mesa alta con sobre y patas de madera de roble.



**Conference room**  
**Sala de reunión**

▼ ME 6206

Table with lacquered board.  
Mesa con tablero lacado.





▼ **BC 6302 + CJ 6322**

Bench with oak wood seat and legs. Three seater upholstered cushion.  
Banco con asiento y patas de madera de roble. Cojín tapizado de tres plazas.

▼ **ME 6158**

Table with solid walnut wood top and legs.  
Mesa con sobre y patas de madera de nogal.



316

Closed

**Workspace**  
**Espacio de trabajo**

▼ **ME 6106**

Table with solid oak wood top and legs.  
Mesa con sobre y patas de madera de roble.



Closed

317



The Colors bases can be used with any model from the Top collection, allowing to create very stable and versatile tables. Both the foot and column are made from steel, with 3 different heights and applicable for either indoor or outdoor.

Las bases Colors, en combinación con cualquier modelo de la colección Top, permiten el desarrollo de mesas de gran estabilidad y versatilidad. Tanto el pie como la columna están realizados en acero, en tres alturas diferentes y pueden utilizarse en interiores o exteriores, indistintamente.

## Colors

by Estudio Andreu







◀ **BM 4551 + SB 4665**  
Steel central base and lacquered top.  
Base central de acero y sobre lacado.

**Restaurant  
Restaurante**

▼ **BM 4551 + SB 3460**  
Steel central base and oak top.  
Base central de acero y sobre de roble.

▶ **BM 4552 + SB 4473**  
Steel central base and lacquered top.  
Base central de acero y sobre lacado.

▶ **BM 4550 + SB 4473**  
Steel central base and lacquered top.  
Base central de acero y sobre lacado.

**Cafeteria  
Cafetería**

▶ **BM 4550 + SB 4584**  
Steel central base and compact HPL  
board top.  
Base central de acero y sobre  
compacto.



320

Colors



Colors

321



Is a lightweight, functional and svelte but very stable base. The oval column, available in two heights, and it's the round injected aluminum base distinguish the design from other bases. The Dual combines with any Top Collection top.

Es una base ligera, esbelta y funcional; siempre muy estable. Dual se diferencia por el rasgo ovalado de su columna, disponible en cuatro alturas, y por su base circular de aluminio inyectado. Combina con cualquier sobre de la colección Top.

## Dual

by Lievore Altherr Molina







**Waiting area**

**Zona de espera**

**◀ BM 3347 + SB 3478 Dual 45**

Aluminum table base in white finish and laminated top.

Base de mesa de aluminio con acabado blanco y sobre laminado.

**Outdoor**

**▼ BM 4361 + SB 4581 Dual 45**

Aluminum table base in white finish and compact board top.

Base de mesa de aluminio con acabado blanco y sobre compacto.





**Outdoor**

◀ **BM 4362+ SB 4580 Dual 45**

Aluminum table base in black finish and compact board top.

Base de mesa de aluminio con acabado negro y sobre compacto.

**Outdoor**

▶ **BM 4362 + SB 4581 Dual 45**

Aluminum table base in black finish and compact board top.

Base de mesa de aluminio con acabado negro y sobre compacto.

▼ **BM 4376 + SB 3942 Dual 45**

Aluminum table base in white finish and laminated top.

Base de mesa de aluminio con acabado blanco y sobre laminado.

▼ **BM 3342 + SB 3479 Dual 45**

Aluminum table base in black finish and laminated top.

Base de mesa de aluminio con acabado negro y sobre laminado.

▼ **BM 3340 + SB 3468 Dual 45**

Aluminum table base in polished aluminum finish and oak top.

Base de mesa de aluminio con acabado aluminio pulido y sobre de roble.







▲ **BM 4392 + SB 4473 Dual 50**  
 Aluminum table base in white finish and lacquered top.  
 Base de mesa de aluminio con acabado blanco y sobre lacado.

**Restaurant**

**Restaurante**

► **BM 3342 + SB 4463 Dual 45**  
 Aluminum table base in black finish and lacquered top.  
 Base de mesa de aluminio con acabado negro y sobre lacado.

**Meeting room**

**Sala de reuniones**

► **BM 4392 + SB 4584 Dual 50**  
 Aluminum table base in white finish and high pressure laminate top (HPL).  
 Base de mesa de aluminio con acabado blanco y sobre compacto laminado de alta presión (HPL).



Dual



Dual



Lightweight, sleek and with the same functional spirit as Dual, this occasional table goes well with sofas and armchairs. The oval shape of the column provides a balanced, timeless and unique design. Dual Occasional is available in two heights and three different shaped tops: round, square and elliptical.

Ligera, esbelta y con el mismo espíritu funcional de Dual, esta mesa auxiliar complementa a sofás y butacas. Tiene un diseño equilibrado, atemporal, singular gracias a la forma ovalada de su columna. Está disponible en dos alturas y tres formas de sobre diferentes, redondo, cuadrado y elíptico.

## Dual Occasional

by Lievore Altherr Molina





► **ME 6392**

Low aluminum central base in matte black finish and lacquered top.  
Base central de aluminio en acabado negro mate con sobre lacado.

► **ME 6356**

Occasional aluminum table in matte white finish and round lacquered top.  
Mesa auxiliar de aluminio en acabado blanco mate y sobre redondo lacado.

**Residential**

**Hogar**

▼ **ME 6366**

Occasional aluminum table in matte black finish and round lacquered top.  
Mesa auxiliar de aluminio en acabado negro mate y sobre redondo lacado.

**Waiting area**

**Zona de espera**

► **ME 6366**

Occasional aluminum table in matte black finish and round lacquered top.  
Mesa auxiliar de aluminio en acabado negro mate y sobre redondo lacado.

► **ME 6375**

Occasional aluminum table in matte black finish and round oak top.  
Mesa auxiliar de aluminio en acabado negro mate y sobre redondo de roble.





Extra is a table system developed to maximize the versatility of its materials, uses and adaptability to various installations. This resulted in a clear goal: a universal table that offers maximum functionality while maintaining its aesthetic value.

Extra es un sistema de mesas desarrollado desde la máxima versatilidad respecto a los materiales, los usos y su adaptación a todo tipo de ambientes. Es el resultado de una búsqueda concreta: una mesa universal que ofrezca siempre la máxima funcionalidad manteniendo su valor estético.

# Extra

by Lievore Altherr Molina





Conference room  
Sala de reunión

▼ ME 8105

Table with oak board top and oak  
legs.  
Mesa con sobre de tablero de roble  
y patas de roble.







◀ **ME 8193**

Table with ceramic top and aluminum legs.  
Mesa con sobre cerámico y patas de aluminio.

**Meeting room**  
**Sala de reunión**

◀ **ME 8855**

Table with carrara marble top and black aluminum legs.  
Mesa con sobre de mármol de carrara y patas de aluminio negro.

**Conference room**  
**Sala de reunión**

▼ **ME 8175**

Table with oak board top and oak legs.  
Mesa con sobre de tablero de roble y patas de roble.



338

Extra

Extra

339



**Conference room**

**Sala de reunión**

**▼ ME 8411**

Table with lacquered top  
and oak legs.

Mesa con sobre lacado y  
patas de roble.







**Workspace**  
**Espacio de trabajo**  
**▲ ME 8411**

Table with lacquered top and legs.  
Mesa con sobre y patas lacadas.

**◀ ME 8108 + PS 0695**

Table with oak top and aluminum delta legs with wire management.  
Mesa con sobre de roble y patas delta de aluminio con sistema de conexiones.

**Workspace**  
**Espacio de trabajo**  
**► ME 8008**

Table with lacquered top and aluminum delta legs.  
Mesa con sobre lacado y patas delta de aluminio.

342

Extra



Extra

343



**Conference room**

**Sala de reunión**

**▼ ME 8280**

Table with oak board top  
and aluminum legs.

Mesa con sobre de  
tablero de roble y patas  
de aluminio.





Plaza is a table base that can combine with any top from our catalog, from a basic shape –available in two heights– made of injected aluminum and with a harmonious solid wood or aluminum column. It features a wide range of finishes that guarantee its capacity to adapt.

Plaza es una base de mesa que se adapta sin problemas a todos los sobres de nuestro catálogo, a partir de una forma esencial –disponible en dos medidas– realizada en aluminio inyectado y de una columna armónica de madera maciza o aluminio.

# Plaza

by Estudio Andreu







◀ **BM 1082 + SB 3477**  
Aluminum base and round column in white finish. Lacquered top.  
Base central con columna redonda y base de aluminio en acabado blanco con sobre lacado.

**Cafeteria  
Cafetería**

▼ **BM 1087 + SB 0871**  
Aluminum base and square column in black finish. Top 23 lacquered top.  
Base central con columna cuadrada y base de aluminio en acabado negro con sobre lacado.

**Educational  
Educativo**

▶ **BM 1104 + SB 0978**  
Aluminum base and square column in matte black finish. Lacquered top.  
Base central con columna cuadrada y base de aluminio en acabado negro mate con sobre lacado.



348

Plaza



Plaza

349



The cross design of the Quattro Collection provides a dynamic and sturdy solution in the most demanding contract environment without sacrificing lightness and performance. Additionally, its reduced size is the perfect solution for the need of a versatile and discreet side table for sofas and lounge chairs.

Su base en cruz le confiere dinamismo y robustez para poder destacar en el contract más exigente sin renunciar a la ligereza y a los detalles de su cuidada ejecución, y su reducido tamaño da respuesta a la necesidad de mesa complementaria para sofás y butacas, con un diseño versátil y contenido.

## Quattro

by Lievore Altherr Molina





► **BM 4729 + SB 4469**

Bar height aluminum central table base and lacquered top.  
Base central alta de aluminio pulido y sobre lacado.

► **BM 4739 + SB 4475**

Aluminum central table base in white finish and lacquered top.  
Base central de aluminio acabado en blanco y sobre lacado.

▼ **BM 4739 + SB 4475**

▼ **BM 4728 + SB 3951**

Aluminum central table base in black finish and elliptic lacquered top.  
Base central con base cuatro aspas de aluminio acabado en negro y sobre elíptico lacado.

▼ **BM 4724 + SB 4471**

Aluminum central table base in white finish and lacquered top.  
Base central ocasional con base cuatro aspas de aluminio acabado en blanco y sobre lacado.

▼ **BM 4729 + SB 4469**

▼ **BM 4734 + SB 3963**

Occasional central base in black finish and elliptic oak top.  
Base central ocasional con base cuatro aspas de aluminio acabado en negro y sobre elíptico de roble.

▼ **BM 4724 + SB 3462**

Occasional central base in white finish and oak top.  
Base central ocasional con base cuatro aspas de aluminio acabado en blanco y sobre de roble.



**Cafeteria**

**Cafetería**

▼ **BM 4726 + SB 3461**

Central base in polished aluminum finish and oak top.  
Base central con base cuatro aspas de aluminio pulido y sobre de roble.





Designed to satisfy the most demanding project needs, the Quattro Occasional table collection stands out for its lightness, sturdiness and dynamic design. Its reduced size makes it ideal as an occasional table next to sofas or armchairs.

Concebida para satisfacer los proyectos más exigentes, la colección de mesas Quattro Occasional destaca por su ligereza, robustez y dinamismo. Su tamaño reducido la hace idónea como mesa auxiliar de sofás y butacas.

## Quattro Occasional

by Lievore Altherr Molina





► **ME 6709**

Occasional aluminum table in matte white finish and square lacquered top.  
Mesa auxiliar de aluminio en acabado blanco mate y sobre cuadrado lacado.

▼ **ME 6774**

Occasional aluminum table in polished aluminum finish and square high pressure laminate top (HPL).  
Mesa auxiliar de aluminio en acabado aluminio pulido y sobre cuadrado laminado de alta presión (HPL).

▼ **ME 6766**

Occasional aluminum table in matte white finish and elliptical marble top.  
Mesa auxiliar de aluminio en acabado blanco mate y sobre elíptico de mármol.

▼ **ME 6725**

Occasional aluminum table in matte black finish and round lacquered top.  
Mesa auxiliar de aluminio en acabado negro mate y sobre redondo lacado.

**Waiting area**

**Zona de espera**

► **ME 6717**

Occasional aluminum table in polished aluminum finish and round lacquered top.  
Mesa auxiliar de aluminio en acabado aluminio pulido y sobre redondo lacado.





Developed in harmony by the Raglan Sofa system, this occasional table has four aluminum legs and a wide variety of tops in different materials. It is discreet, and functional.

Desarrollada junto al programa de sofás Raglan, esta mesa auxiliar cuenta con una base de cuatro patas de aluminio y con una gran variedad de sobres de distintos materiales. Es discreta, esencial y funcional.

## Raglan Table

by Piergiorgio Cazzaniga







◀ **ME 8525**  
Occasional table with four aluminum legs in black matte finish and lacquered top.  
Mesa ocasional con base de cuatro patas de aluminio en acabado negro mate y sobre lacado.

◀ **ME 8627**  
Occasional table with four aluminum legs in black matte finish and marble top.  
Mesa ocasional con base de cuatro patas de aluminio en acabado negro mate y sobre de mármol.

◀ **ME 8627**  
Occasional table with four aluminum legs in black matte finish and marble top.  
Mesa ocasional con base de cuatro patas de aluminio en acabado negro mate y sobre de mármol.

**Waiting area  
Zona de espera**

◀ **ME 8525**  
Occasional table with four aluminum legs in black matte finish and lacquered top.  
Mesa ocasional con base de cuatro patas de aluminio en acabado negro mate y sobre lacado.

◀ **ME 8627**  
Occasional table with four aluminum legs in black matte finish and marble top.  
Mesa ocasional con base de cuatro patas de aluminio en acabado negro mate y sobre de mármol.

**Waiting area  
Zona de espera**

▼ **ME 8525**  
Occasional table with four aluminum legs in black matte finish and lacquered top.  
Mesa ocasional con base de cuatro patas de aluminio en acabado negro mate y sobre lacado.

▼ **ME 8627**  
Occasional table with four aluminum legs in black matte finish and marble top.  
Mesa ocasional con base de cuatro patas de aluminio en acabado negro mate y sobre de mármol.





This program of tables, developed from an elaborate and synthetic geometry, is the epitome of versatility and adaptation to a multitude of environments and workspaces. Radial Table Conference is characterized by its modularity and technology. Its architectural design and distinct technological character adapts to a multitude of combinations, offering power management integrated into the table's structure.

Este programa de mesas, desarrollado a partir de una geometría trabajada y sintética, es el paradigma de la versatilidad y la adaptación a multitud de entornos y espacios de trabajo. Radial Conference Table se caracteriza por su modularidad y tecnificación. Su diseño arquitectónico y de marcado carácter tecnológico se adapta a multitud de combinaciones, ofreciendo una gestión de las conexiones integradas a su estructura.

## Radial Conference Table

by Estudio Andreu





**Conference room  
Sala de reuniones**

**▼ ME 9072**

Aluminum legs in black finish with oak top.  
Patas de aluminio acabadas en negro  
con sobre de roble.





► **ME 9330**

Aluminum legs in white finish with lacquered top.  
Patas de aluminio acabadas en blanco con sobre lacado.

▼ **ME 9168**

Aluminum legs in black finish with oak top.  
Patas de aluminio acabadas en negro con sobre de roble.

**Conference room**

**Sala de reunión**

► **ME 9195**

Aluminum legs in white finish with lacquered top.  
Patas de aluminio acabadas en blanco con sobre lacado.





**Workspace**  
**Zona de trabajo**

► **ME 95128**

High table. Aluminum legs in black finish with laminate top.  
Mesa alta. Patas de aluminio acabadas en negro con sobre laminado.

▼ **ME 95056**

High table. Aluminum legs in white finish with lacquered top.  
Mesa alta. Patas de aluminio acabadas en blanco con sobre lacado.

**Workspace**  
**Zona de trabajo**

► **ME 95128**

High table. Aluminum legs in black finish with lacquered top.  
Mesa alta. Patas de aluminio acabadas en negro con sobre lacado.

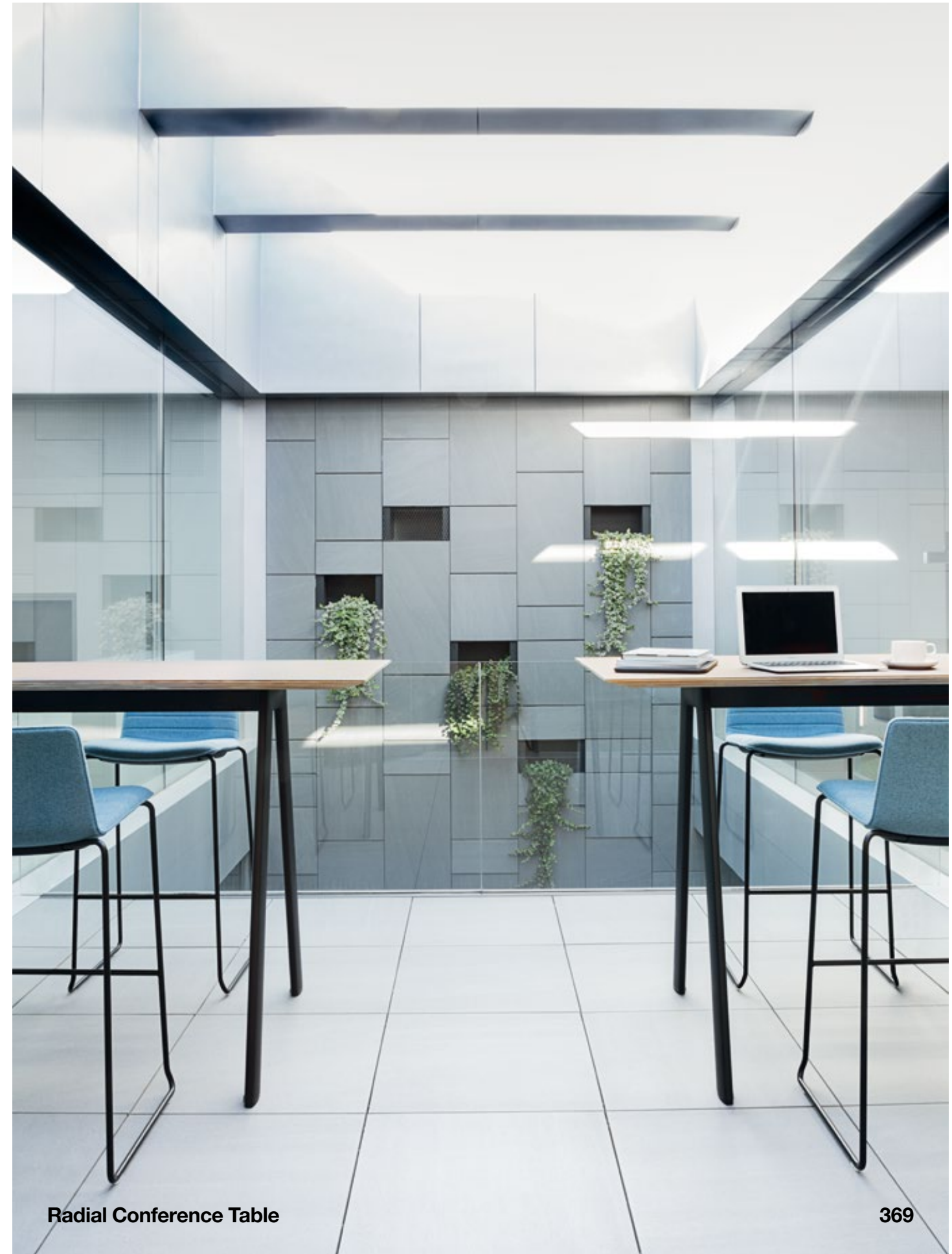



Created from a very basic shape, the Reverse Collection of bases is a symbol of elegance and structural stability. Made from 100% recyclable polyethylene, Reverse bases combine perfectly with a wide range of tops of diverse finishes and functions.

Formulada a partir de una forma esencial, la colección de bases Reverse es un icono de elegancia y estabilidad estructural. Realizadas a partir de polietileno 100% reciclable, las bases Reverse combinan a la perfección con una gran variedad de sobres de acabados y prestaciones muy diversos.

## Reverse

by Piergiorgio Cazzaniga





► **BM 4562 Reverse 42 + SB 4583**

Polyethylene central base in black matte finish with high pressure laminate top (HPL).

Base central en polietileno acabado en negro mate con sobre laminado de alta presión (HPL).

**Cafeteria**

**Cafetería**

▼ **BM 4520 Reverse 38 + SB 3462**

Polyethylene central base in matte finish with solid oak top.

Base central en polietileno acabado mate con sobre de roble.

**Meeting room**

**Sala de reunión**

► **BM 4521 Reverse 50 + SB 0956**

Polyethylene central base in black finish with lacquered top.

Base central en polietileno acabado en negro con sobre lacado.

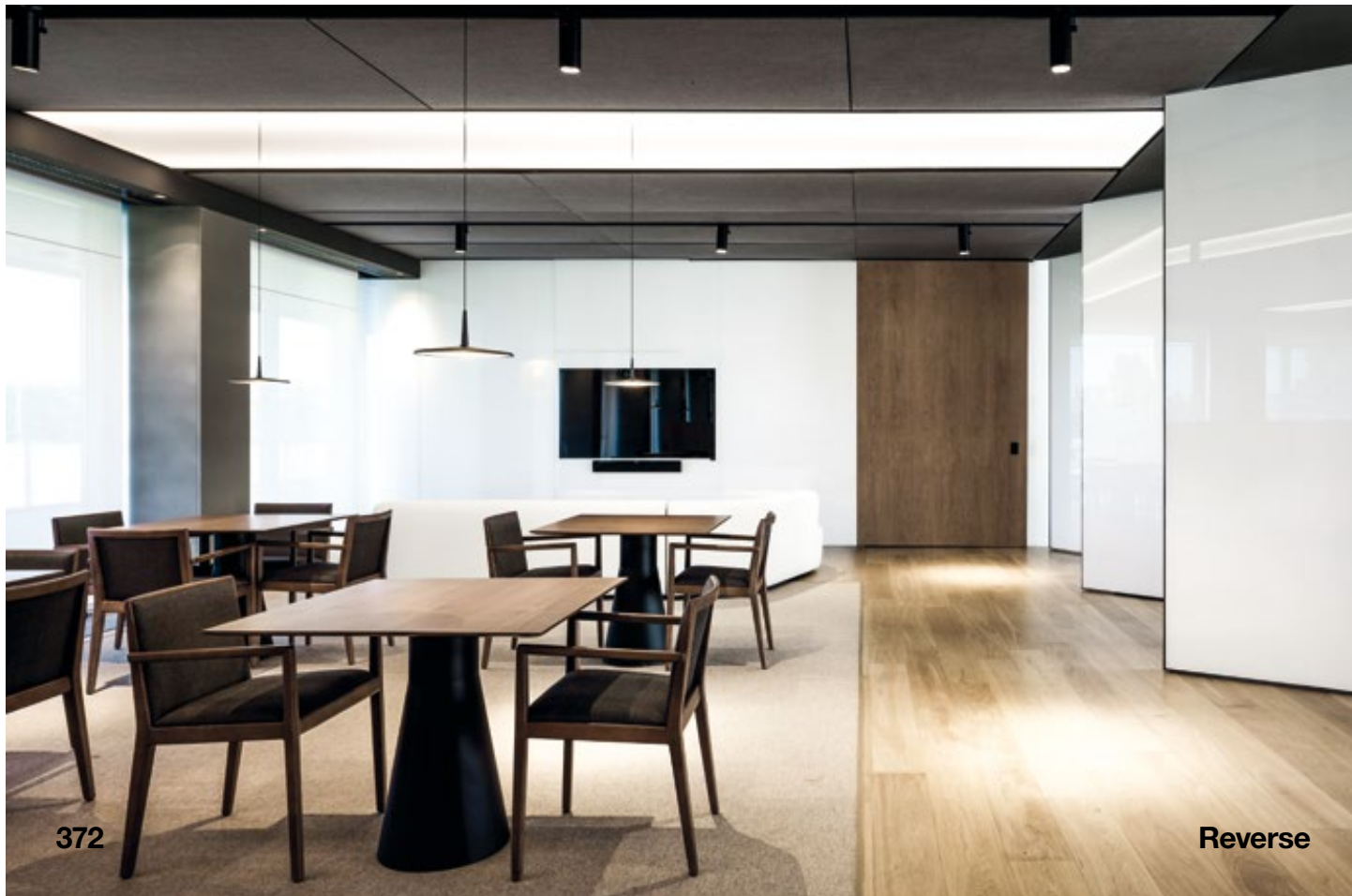





**Outdoor**

**◀ BM 4520 Reverse 38 + SB 4581**

Polyethylene central base in white matte finish with high pressure laminate top (HPL).  
Base central en polietileno acabado en blanco mate con sobre compacto laminado de alta presión (HPL).

**Outdoor**

**▼ BM 4520 Reverse 38 + SB 4582**

Polyethylene central base in black matte finish with high pressure laminate top (HPL).  
Base central en polietileno acabado en negro mate con sobre compacto laminado de alta presión (HPL).





Reverse is one of our most iconic and versatile table. Now the collection has been expanded to include an occasional table, in two base heights and two table top diameters.

Reverse es una de nuestras mesas más icónicas y versátiles. Ahora ha evolucionado como mesa ocasional, con dos alturas de base y dos diámetros de sobre.

## Reverse Occasional

by Piergiorgio Cazzaniga





**Waiting area**  
**Sala de espera**  
**Reverse Occasional 55**  
**▼ ME 5128**

Polyethylene central base in matte black finish with marble top.

Base central en polietileno acabado negro mate con sobre de mármol.

**Reverse Occasional 45**  
**▼ ME 5110**

Polyethylene central base in matte black and lacquered top.

Base central en polietileno acabada en negro mate y sobre lacado.



**Waiting area**  
**Zona de espera**  
**Reverse Occasional 55**  
**▼ ME 5128**

Polyethylene central base in matte black finish with marble top.

Base central en polietileno acabado negro mate con sobre de mármol.

**Reverse Occasional 45**  
**▼ ME 5110**

Polyethylene central base in matte black finish with lacquered top.

Base central en polietileno acabado negro mate con sobre lacado.

**Reverse Occasional 55**  
**▼ ME 5125**

Polyethylene central base in matte black finish with lacquered top.

Base central en polietileno acabado negro mate con sobre lacado.





**Reverse Occasional 35**

▼ **ME 5327**

Polyethylene central base in matte white finish with marble top.

Base central en polietileno acabado en blanco mate con sobre de mármol.

**Waiting area**

**Sala de espera**

**Reverse Occasional 35**

► **ME 5327**

Polyethylene central base in matte black finish with marble top.

Base central en polietileno acabado negro mate con sobre de mármol.

**Reverse Occasional 45**

► **ME 5110**

Polyethylene central base in matte black and lacquered top.

Base central en polietileno acabada en negro mate y sobre lacado.

**Reverse Occasional 55**

► **ME 5128**

Polyethylene central base in matte black finish with marble top.

Base central en polietileno acabado negro mate con sobre de mármol.





The versatility of the Reverse system is its ability to be combined with table tops of different sizes, finishes, formats and materials. This aspect and its numerous electric and multimedia solutions meets all requirements for today's workspace.

La versatilidad de este programa de mesas se basa en sus posibilidades de combinación. Los sobres, de diferentes tamaños, acabados, formatos y materiales y las bases, realizadas en polietileno, se ofrecen en distintos colores y acabados. Se completa con soluciones integrales de conectividad eléctrica y multimedia.

## Reverse Conference Table

by Piergiorgio Cazzaniga





**Conference room**

**Sala de reunión**

**▼ ME 5022**

Elliptical oak top and three central  
bases.

Sobre elíptico de roble y tres  
bases centrales.







**Conference room**  
**Sala de reunión**  
**▼ ME 5034**  
Elliptical lacquered top and three central bases.  
Sobre elíptico lacado y tres bases centrales.



**Conference room  
Sala de reunión**

▼ ME 5017

Elliptical lacquered top and two central bases.  
Sobre elíptico lacado y dos bases centrales.



**Conference room  
Sala de reunión**

▼ ME 5023

Elliptical oak top and three central bases.  
Sobre elíptico de roble y tres bases centrales.





The versatility of the Reverse system is its ability to be combined with table tops of different sizes, finishes, formats and materials. This aspect and its numerous electric and multimedia solutions meets all requirements for today's workspace.

La versatilidad de este programa de mesas se basa en sus posibilidades de combinación. Los sobres, de diferentes tamaños, acabados, formatos y materiales y las bases, realizadas en polietileno, se ofrecen en distintos colores y acabados. Se completa con soluciones integrales de conectividad eléctrica y multimedia.

## Reverse Conference Lounge

by Piergiorgio Cazzaniga





▼ ME 5736

Round cement top and cement central base.  
Sobre redondo de cemento y base central de cemento.



▼ ME 5013

Elliptical oak top and two central bases.  
Sobre elíptico de roble y dos bases centrales.



▼ ME 5537

Round glass top and one central base.  
Sobre redondo de cristal y una base central.





SP is a flexible, multipurpose wood table system that can adapt to the most diverse environments thanks to its different shapes, sizes and heights. The SP Collection is the perfect solution for offices, public spaces or waiting rooms.

SP es un sistema de mesas flexible y polivalente, capaz de adaptarse a los ambientes más diversos a partir de su oferta de distintas formas, longitudes y alturas. Es una solución perfecta para oficinas, espacios públicos o zonas de espera.

## Sistema SP

by Lievore Altherr Molina







396

Sistema SP

**Restaurant  
Restaurante**

◀ SB 7139 + BM 7215

Square maple top with four  
beech legs.  
Sobre cuadrado de arce con  
cuatro patas de haya.

**Conference room  
Sala de reunión**

▼ SB 7150 + BM 7215

Rectangular maple top with  
four beech legs.  
Sobre rectangular de arce con  
cuatro patas de haya.



Sistema SP

397



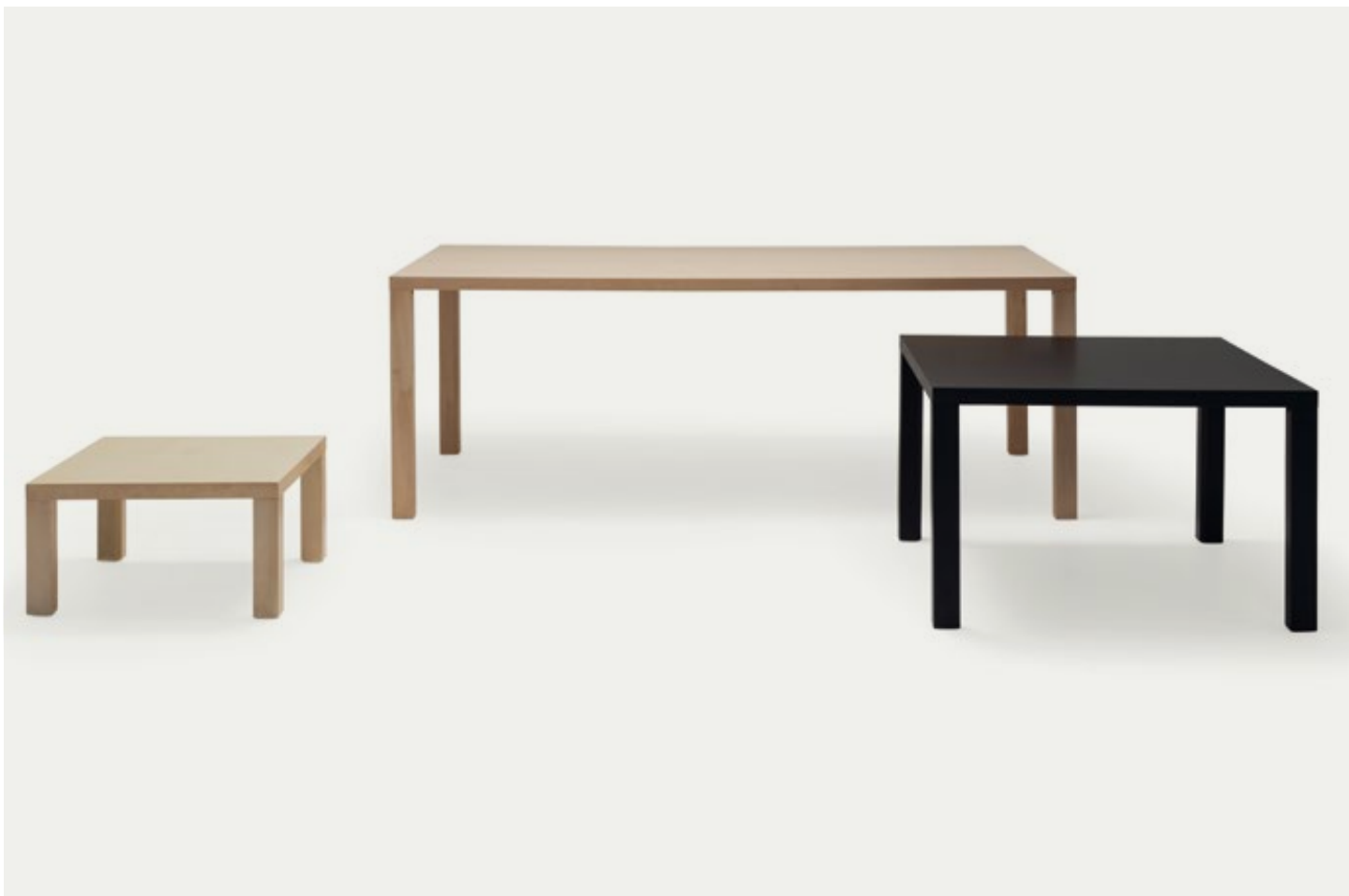

◀ **SB 7158 + BM 7217**

Occasional table. Square maple top with four beech legs.

Mesa auxiliar. Sobre cuadrado de arce con cuatro patas de haya.

◀ **SB 7150 + BM 7215**

Rectangular maple top with four beech legs.

Sobre rectangular de arce con cuatro patas de haya.

◀ **SB 7234 + BM 7183**

Occasional table. Square lacquered top with four beech legs.

Mesa ocasional. Sobre cuadrado lacado con cuatro patas de haya.

**Residential**

**Hogar**

◀ **SB 7150 + BM 7215**

Rectangular maple top with four beech legs.

Sobre rectangular de arce con cuatro patas de haya.

**Residential**

**Hogar**

▼ **SB 7233 + BM 7184**

Lacquered square top and legs.

Sobre cuadrado y patas lacadas.





Tao is a powerful symbol that can attract all the attention and impose its personality on a space. Made in oak wood, Tao is sculptural piece that combines simplicity and uniqueness.

Tao es un signo poderoso capaz de capturar todas las miradas y de imponer su personalidad en un espacio. Realizada en madera de roble, Tao es escultural y propone una forma única que aúna sobriedad y singularidad.

# Tao

by Lievore Altherr Molina





▼ **ME 3111**

Oak top and base in solid oak wood.  
Sobre de roble y base de madera maciza de roble.

**Home office**

► **ME 3110**

Oak top and base in solid oak wood.  
Sobre de roble y base de madera maciza de roble.



402

Tao



Tao

403



It expresses the nobility and sturdiness of wood in a clear, contemporary language. It adapts to all kinds of residential or business environments and easily blends in with all of our chair collections.

Expresa la nobleza y la rotundidad de la madera con un lenguaje claro y contemporáneo. Se adapta a todo tipo de ambientes, residenciales o de contract, y armoniza sin problemas con todas nuestras colecciones de sillas.

# Uves

by Lievore Altherr Molina





Conference room  
Sala de reunión  
▼ ME 3665  
Oak top and base in solid  
oak wood.  
Sobre de roble y base de  
madera maciza de roble.





▼ ME 3664

Oak top and base in solid oak wood.  
Sobre de roble y base de madera maciza de roble.

Residential

Hogar

► ME 3661

Oak top and base in solid oak wood.  
Sobre de roble y base de madera maciza de roble.





An occasional table can also be very iconic. Uves Occasional expresses the nobility of solid wood with a contained, elegant design. The two base heights increase the versatility of this exemplary table.

Una mesa auxiliar también puede resultar muy representativa. Uves Occasional expresa la nobleza de la madera maciza en un diseño contenido y elegante. Sus dos alturas de base diferentes aumentan la versatilidad de esta mesa emblemática.

## Uves Occasional

by Lievore Altherr Molina





▼ **ME 3686 Uves**  
▼ **ME 3697 Uves Ocasional**  
Occasional table made of solid oak base and top.  
Mesa ocasional con sobre base de madera de roble.

► **ME 3697 Uves Ocasional**  
► **ME 3686 Uves**





The possibilities of the Top Collection are so vast that they can satisfy any interior design need. The traditional square and circular shapes are complemented by an elliptical design developed by carefully combining four different ellipses in a single gesture. They include materials of great resistance and high durability suitable to give solutions to different surfaces of tables as workspaces, hospitality or residential.

Las colecciones Top son tan extensas que pueden satisfacer cualquier necesidad en el ámbito del diseño de interiores. A las formas tradicionales, cuadrada y circular, se suma también la elíptica. Incluyen materiales de gran resistencia y alta durabilidad idóneo para dar soluciones a diferentes superficies de mesas como zonas de trabajo, instalación o residencial.

## Tops







◀ **Technical Stone**

6 mm./0.25 in. layer ceramic table top. Colors: Earth Brown, Sand Grey, Stone Grey. Available for all table base collections. Suitable for outdoor use. Tablero de mesa cerámico de 6 mm. Colores: Marrón Tierra, Gris Arena, Gris Piedra. Válido para cualquier colección de columna central. Válido para su uso en exterior.

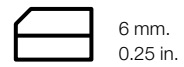

◀ **Top Compacto HPL**

12 mm/ 0.50 in thick Compacto high pressure laminated (HPL) table top. Suitable for outdoor and high traffic areas. Colors: Black N201 and White B200. Available for all table base collection. Tablero Compacto laminado de alta presión (HPL) de 12 mm/ 0.50 in. Válido para exterior y áreas de uso intenso. Colores: Negro N01 y Blanco B200. Válido para cualquier base de columna central.

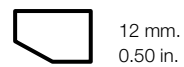

◀ **Top Solid Surface**

12 mm. / 0.50 in thick solid surface table top. Available in Glacier White color. Able to be combined with all column basecollections. Suitable for outdoor use. Sobre de solid surface de 12 mm. de espesor. Disponible en color Glacier White. Válido para cualquier colección de columnas. Válido para uso en exterior.

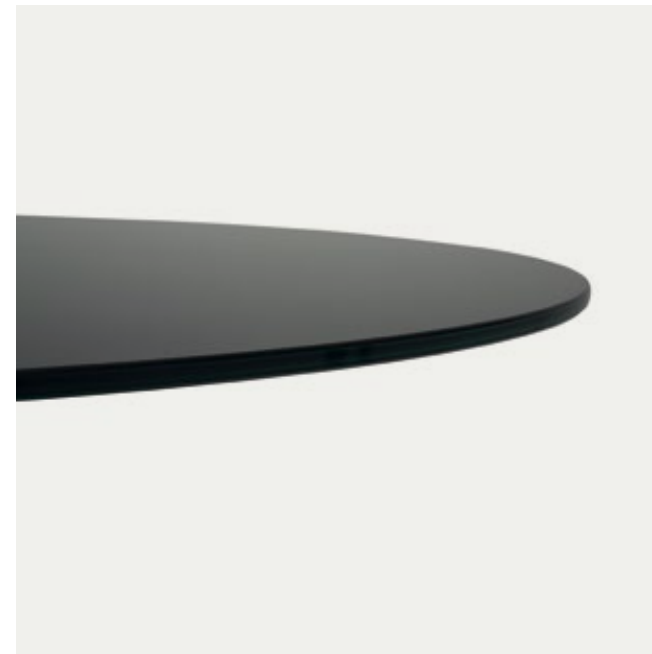

◀ **Top Glass**

10 mm. / 0.50 in. thick tempered glass table top available in several colors and gloss finish. Optional glass version available. Suitable to be combined with all the central column table base collections. Suitable for outdoor use. Sobre de mesa de cristal templado de 10 mm. de espesor, disponible en varios colores y acabado brillo. Se ofrece una versión de cristal óptico. Válido para cualquier colección de columna central y su uso en exterior.







◀ **Top 18**

Top 18 Oak / Roble  
18 mm./0.75 in. top made of oak veneer. Suitable for all table base collections.  
Tablero contrachapado de 18 mm. chapado en roble. Válido para cualquier base de columna central.

Top 18 Laminated / Laminado  
18 mm. laminated top that is suitable for high traffic areas. Suitable to be combined with all central column base collections.  
Tablero contrachapado de 18 mm. laminado preparado para áreas de uso intenso. Válido para cualquier base de columna central.

Top 18 Lacquered / Lacado  
18 mm. lacquer top. Suitable for all table base collections.  
Tablero de 18 mm. lacado. Válido para cualquier base de columna central.

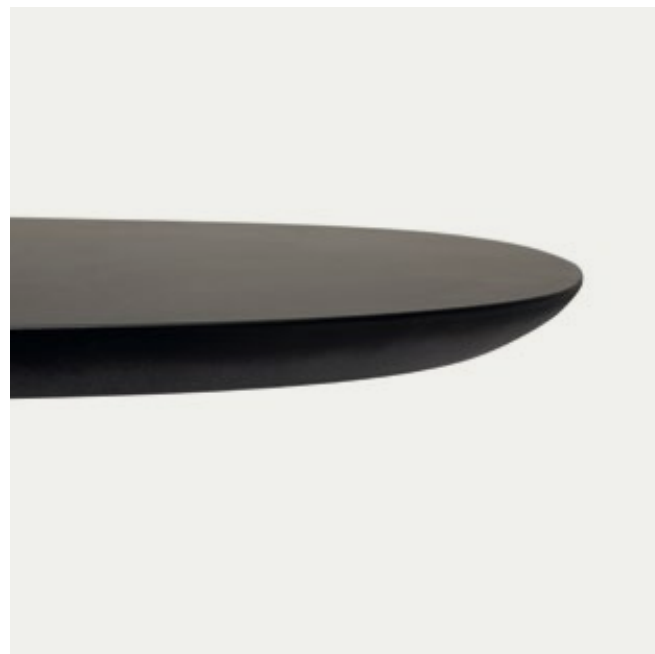

◀ **Top 23**

23 mm./1 in. thick two face table top finished in a maple veneer. Can be combined with all table base collections.  
Sobres de mesa 23 mm. chapados en arce a dos caras. Válidos para cualquier colección de columna central.

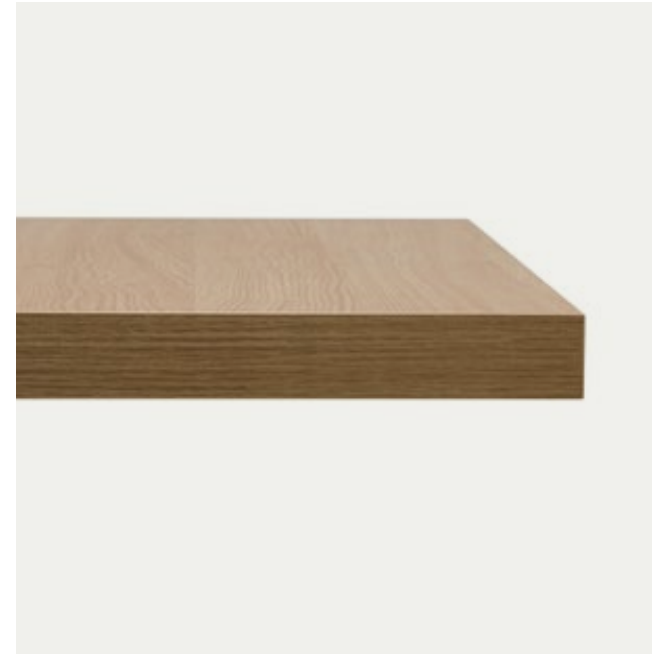

◀ **Top 30**

Laminate table top, 30 mm / 1.18 in thickness, available in various finishes and matching thermopolymer edge. Suitable for any central column base.  
Sobre de mesa laminado de 30mm de espesor disponible en diferentes acabados y con canto de termopolímero a juego. Válido para cualquier base de columna central.

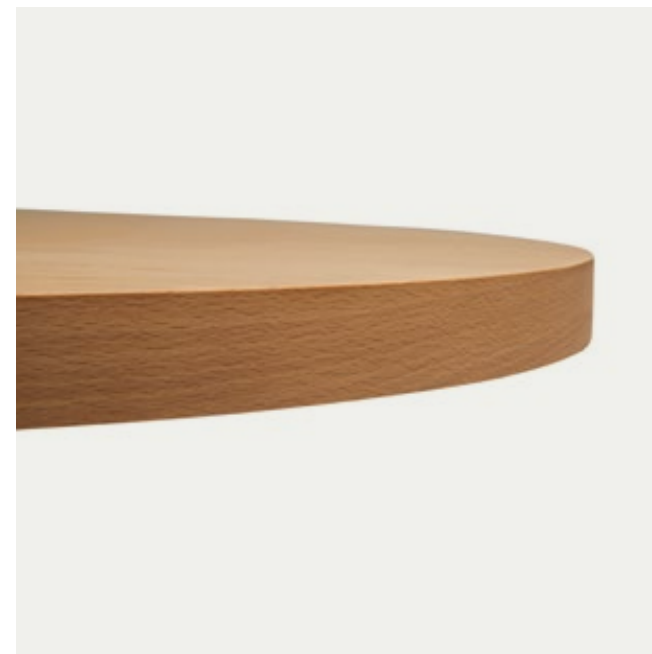
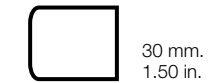

◀ **Top SP 40**

40 mm./1.75 in. thick table top with maple veneer on both sides with solid edges. Available for all table base collections.  
Sobres fijos de 40 mm. chapados en arce con cantos macizos. Válido para cualquier colección de columna central.

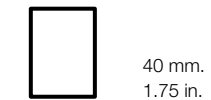





◀ **Top 60**  
Two face table tops 60 mm./2.35 in. thick maple veneer tops. Available for all table base collections.  
Sobres de mesa de 60mm. chapados en arce a dos caras. Válidos para cualquier colección de columna central.

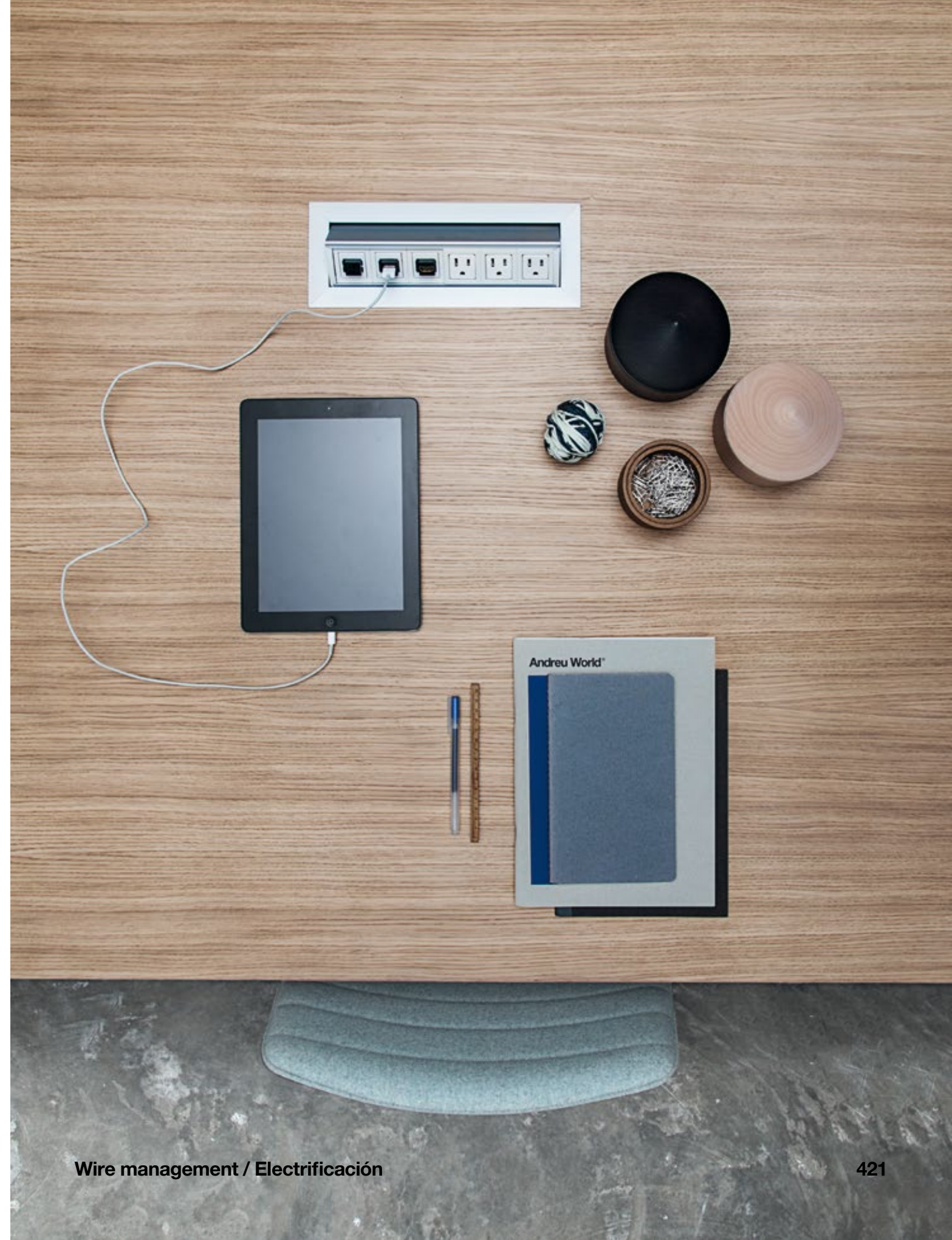
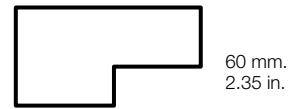



## Closed

### Surface mounted power boxes

Aluminum power box integrated into the surface of the table with hinged lid. Available for all models of the Closed Table collection. It is offered in two different sizes and power/data ports can be customized according to the following diagram.

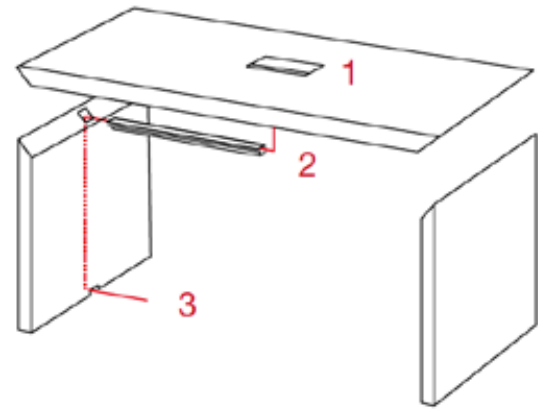

### Cajas de conexiones dentro del sobre

Caja de conexiones de aluminio integrada dentro de la superficie del sobre con tapa abatible. Disponible para todos los modelos de la colección Closed. Se sirve en color anodizado plata, para otros acabados consultar al Departamento Comercial. Se ofrecen formatos de caja de dos tamaños diferentes y con opciones de conectividad configurable de acuerdo con el siguiente esquema.

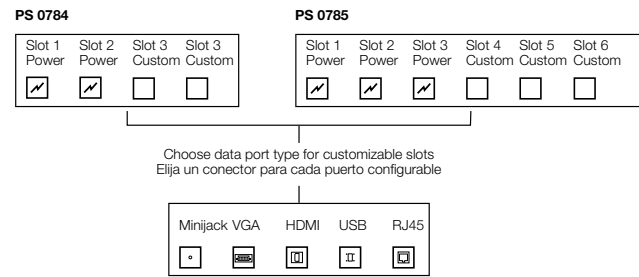

### 1 Power boxes distribution

By standard, the power/data box would be offset relative to the base. For tables with more than one power box, these will be separated 1/3 between them and placed horizontally and longitudinally.

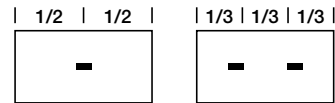

### Distribución de sistemas

De serie, el sistema de conexiones se dispondrá en el centro de la mesa. Para las mesas con más de un sistema, estos se colocarán con una separación de 1/3 de la longitud total de la mesa y en sentido longitudinal.

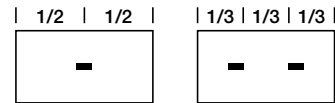

### 2 Wiring management

The cable passes through an aluminum wire manager, keeping it hidden from the users.

### Gestión del cableado

El cable pasa a través de un perfil de aluminio que lo mantiene oculto.

### 3 Wiring exit

The cable exits directly from the power system or through an aluminum frame so that it is concealed at the bottom of the base. The cable then crosses the aluminum profiles of the legs and is completely hidden until it reaches the floor.

### Salida del cableado

La salida del cable se realiza directamente desde el propio sistema de conexiones o a través de un perfil de aluminio en la parte inferior de la base y luego se introduce por los perfiles de aluminio de las patas de modo que el cable queda oculto totalmente hasta llegar al suelo.

## Closed

### Under table power boxes

Power box mounted under the table top, available for all Closed Table models. Available in black color, for other finish options contact the Customer Service Department. The power box is available in two different sizes and the configuration of the power/data slots are customizable as shown in the diagram below.

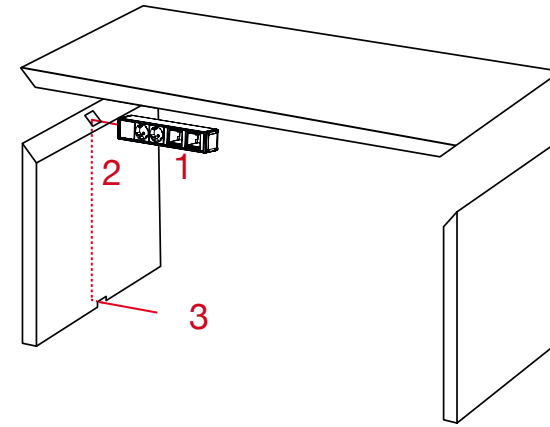

### Cajas de conexiones en la parte inferior del sobre

Regleta de conexiones bajo la superficie del sobre. Se sirve en color negro. Para otros acabados consultar al departamento comercial. Se ofrecen formatos de caja de dos tamaños de caja diferentes y con opciones de conectividad configurable según el siguiente esquema.

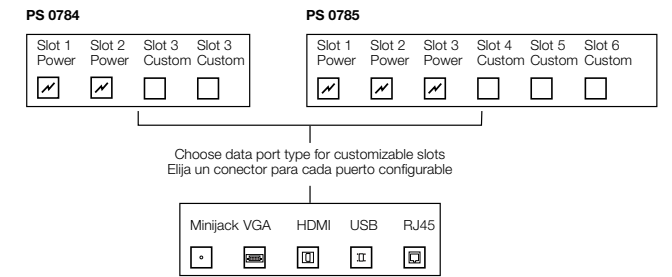

### 1 Power boxes distribution

The location for under table power box is the left side of the table, oriented to the other table leg. Wiring pre-installation will be located in the same leg. For alternative distributions, ask the Customer Service Department.



### Distribución de sistemas

De serie, el sistema se instala a la izquierda de la mesa, orientado hacia la pata opuesta, y el cable bajaría por la misma pata. Para distribuciones especiales consultar al Departamento Comercial.

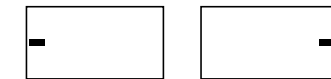

### 2 Wiring management

The cable passes through an aluminum wire manager, keeping it hidden from the users. The standard color is silver, for other finishes, contact the Customer Department.

### Gestión del cableado

El cable pasa a través de un perfil pasacables de aluminio que lo mantiene oculto. Su color de serie es plata, para otros acabados consultar al Departamento Comercial.

### 3 Wiring exit

The cable exits directly from the power system or through an aluminum frame so that it is concealed at the bottom of the base. The cable then crosses the aluminum profiles of the legs and is completely hidden until it reaches the floor.

### Salida del cableado

La salida del cable se realiza directamente desde el propio sistema de conexiones o a través de un perfil de aluminio en la parte inferior de la base y luego se introduce por los perfiles de aluminio de las patas de modo que el cable queda oculto totalmente hasta llegar al suelo.



## Extra

### Surface mounted power boxes

Aluminum power box integrated into the surface of the table with hinged lid. Available for all models of the Extra Table collection. It is available in anodized silver color. For other finishes consult with the Commercial Department. It is offered in two different sizes and power/data ports can be customized according to the following diagram.

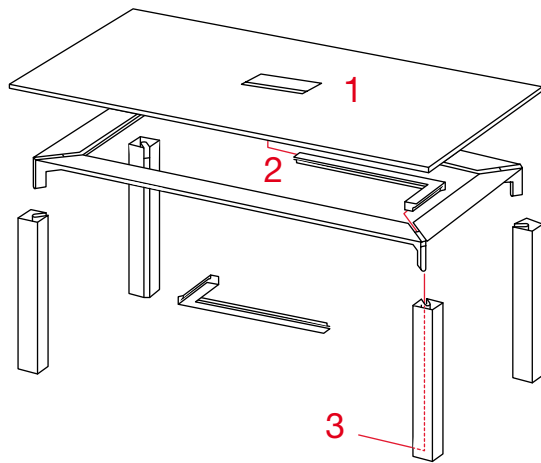

### Cajas de conexiones dentro del sobre

Caja de conexiones de aluminio integrada dentro de la superficie del sobre con tapa abatible. Disponible para todos los modelos de la colección Extra. Se sirve en color anodizado plata, para otros acabados consultar al Departamento Comercial. Se ofrecen formatos de caja de dos tamaños diferentes y con opciones de conectividad configurable de acuerdo con el siguiente esquema.

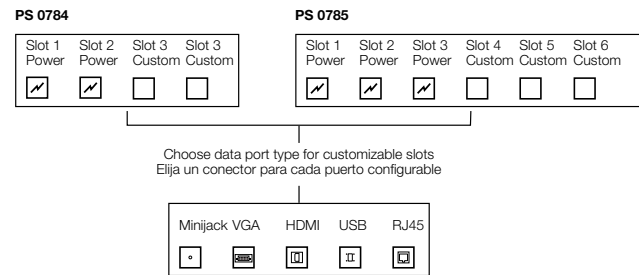

### 1 Power boxes distribution

By standard, the power/data box would be offset relative to the base. For tables with more than one power box, these will be separated 1/3 between them and placed horizontally.

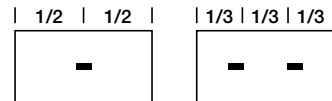

### Distribución de sistemas

De serie, el sistema de conexiones se dispondrá en el centro de la mesa. Para las mesas con más de un sistema, estos se colocarán con una separación de 1/3 de la longitud total de la mesa y en sentido longitudinal.

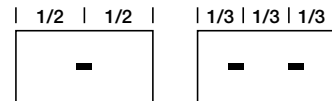

### 2 Wiring management

The cable passes through an aluminum wire manager, keeping it hidden from the users.

El cable pasa a través de un perfil de aluminio que lo mantiene oculto.

### 3

The cable exits directly from the power system or through an aluminum frame so that it is concealed at the bottom of the base. The cable then crosses the aluminum profiles of the legs and is completely hidden until it reaches the floor.

La salida del cable se realiza directamente desde el propio sistema de conexiones o a través de un perfil de aluminio en la parte inferior de la base y luego se introduce por los perfiles de aluminio de las patas de modo que el cable queda oculto totalmente hasta llegar al suelo.

## Radial Conference Table

### Surface mounted power boxes

Aluminum power box integrated into the surface of the table with hinged lid. Available for all models of the Radial Conference Table collection. It is available in anodized silver color. For other finishes consult with the Commercial Department. It is offered in two different sizes and power/data ports can be customized according to the following diagram:

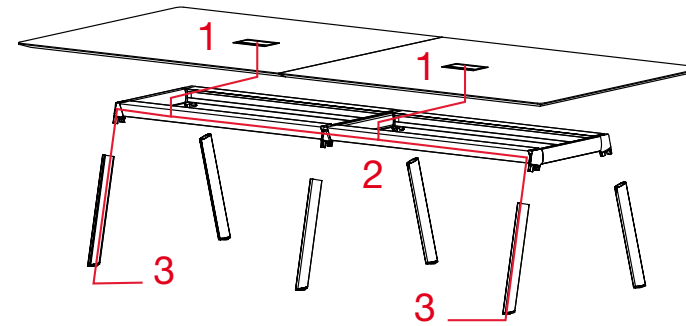

### Cajas de conexiones dentro del sobre

Caja de conexiones de aluminio integrada dentro de la superficie del sobre con tapa abatible. Se sirve en color anodizado plata, para otros acabados consultar al Departamento Comercial. Se ofrecen formatos de caja de dos tamaños diferentes y con opciones de conectividad configurable según el siguiente esquema.

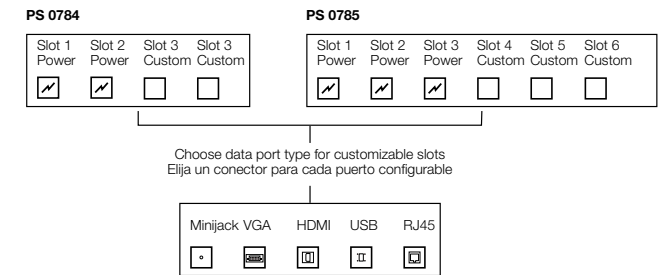

### 1 Power boxes distribution

By standard, the power/data box would be offset relative to the base. For tables with more than one power box, these will be separated 1/3 between them and placed horizontally.

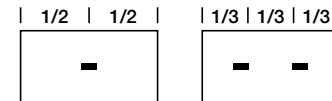

### Distribución de sistemas

De serie, el sistema de conexiones se dispondrá en el centro de la mesa. Para las mesas con más de un sistema, estos se colocarán con una separación de 1/3 de la longitud total de la mesa y en sentido longitudinal.

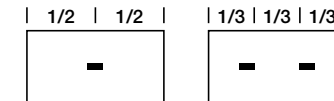

### 2 Wiring management

The cable passes through an aluminum wire manager, keeping it hidden from the users.

### Gestión del cableado

El cable pasa a través de un perfil de aluminio que lo mantiene oculto.

### 3

The cable exits directly from the power system or through an aluminum frame so that it is concealed at the bottom of the base. The cable then crosses the aluminum profiles of the legs and is completely hidden until it reaches the floor.

La salida del cable se realiza directamente desde el propio sistema de conexiones o a través de un perfil de aluminio en la parte inferior de la base y luego se introduce por los perfiles de aluminio de las patas de modo que el cable queda oculto totalmente hasta llegar al suelo.



## Reverse Conference / Reverse Lounge

### Surface mounted power boxes

Power column mounted in the table top. The hidden system automatically rises with a slight push. Valid for Reverse tables with bases Reverse 50 and 60. Available in silver color, for other finishes, contact the Customer Department.

### Cajas de conexiones dentro del sobre

Torre de conexiones integrada dentro de la superficie del sobre. El sistema eléctrico oculto se alza automáticamente al pulsarlo. Disponible mesas Reverse con bases Reverse 50 y 60. Se sirve en color plata, para otros acabados consultar al Departamento Comercial.

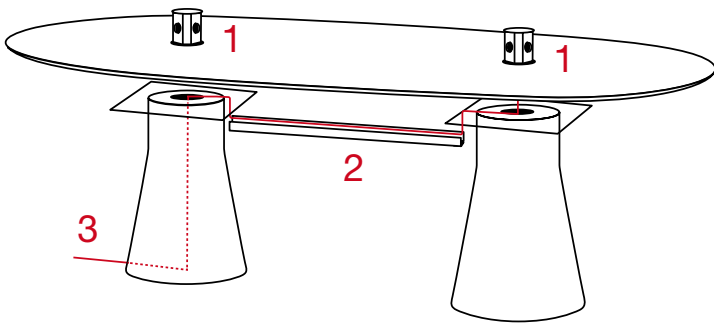

PS 0699

Slot 1 Power	Slot 2 Power	Slot 3 Power	RJ45	RJ45
<input checked="" type="checkbox"/>	<input checked="" type="checkbox"/>	<input checked="" type="checkbox"/>	<input type="checkbox"/>	<input type="checkbox"/>

### 1 Power boxes distribution

By default, power columns are centered with the Reverse base.

### Distribución de sistemas

De serie la columna de electrificación se coloca coincidiendo con la base Reverse.

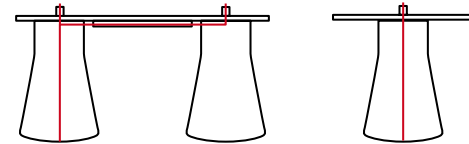
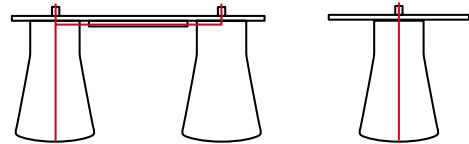

### 2

The cable passes through an aluminum wire manager, keeping it hidden from the users.

### Gestión del cableado

El cable pasa a través de una regleta de aluminio que lo mantiene oculto.

### 3

#### Wiring exit

The cable exits directly the power system or through a channel in the base so that it remains hidden until it reaches the floor.

#### Salida del cableado

La salida del cable se realiza directamente desde el propio sistema a través de la base, de modo que el cable queda oculto hasta llegar al suelo.

## Reverse Conference / Reverse Lounge

### Surface mounted power boxes

Aluminum power box integrated into the surface of the table with hinged lid. Available for all models of the Reverse collection. It is offered in two different sizes and power/data ports can be customized according to the following diagram.

### Cajas de conexiones dentro del sobre

Caja de conexiones de aluminio integrada dentro de la superficie del sobre con tapa abatible. Disponible para todos los modelos de la colección Reverse. Se ofrecen formatos de caja de dos tamaños diferentes y con opciones de conectividad configurable según el siguiente esquema.

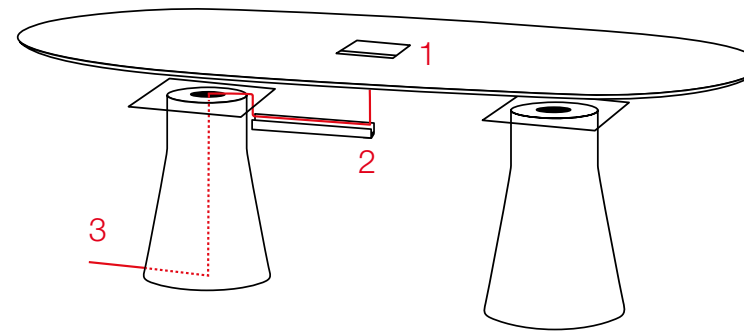

PS 0784

Slot 1 Power	Slot 2 Power	Slot 3 Custom	Slot 3 Custom
<input checked="" type="checkbox"/>	<input checked="" type="checkbox"/>	<input type="checkbox"/>	<input type="checkbox"/>

PS 0785

Slot 1 Power	Slot 2 Power	Slot 3 Power	Slot 4 Custom	Slot 5 Custom	Slot 6 Custom
<input checked="" type="checkbox"/>	<input checked="" type="checkbox"/>	<input checked="" type="checkbox"/>	<input type="checkbox"/>	<input type="checkbox"/>	<input type="checkbox"/>

Choose data port type for customizable slots  
Elija un conector para cada puerto configurable

Minijack	VGA	HDMI	USB	RJ45
<input type="checkbox"/>	<input type="checkbox"/>	<input type="checkbox"/>	<input type="checkbox"/>	<input type="checkbox"/>

### 1 Power boxes distribution

In tables with a single base the power/data box would be offset relative to the base. For tables with more than one base, the box would be longitudinally centered as the default position. If more than one power box is requested, communicate the desired position to the Customer Service Department.

### Distribución de sistemas

En mesas con una sola base el sistema de conexiones se instalará centrado respecto a la base. En mesas con más de una base, por defecto la posición del sistema irá en el centro de la mesa y en sentido longitudinal. Si se solicita más de una sistema de conexiones, comunicar la posición deseada al Departamento Comercial.

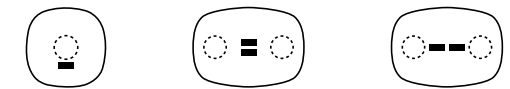
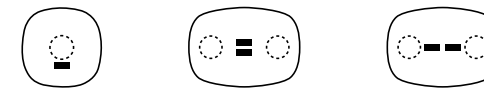

### 2 Wiring management

The cable passes through an aluminum wire manager, keeping it hidden from the users.

### Gestión del cableado

El cable pasa a través de una regleta de aluminio que lo mantiene oculto.

### 3 Wiring exit

The cable exits directly the power system or through a channel in the base so that it remains hidden until it reaches the floor.

#### Salida del cableado

La salida del cable se realiza directamente desde el propio sistema a través de la base, de modo que el cable queda oculto hasta llegar al suelo.



## Reverse Occasional

### Surface mounted power boxes

Power box mounted under the table top, available for any Reverse Occasional model. Available in black color, for other finishing, contact the Customer Department. Data slot can be customized according to the below diagram:

### Cajas de conexiones dentro del sobre

Regleta de conexiones montada bajo la superficie del sobre disponible para cualquier modelo de mesa Reverse Occasional. Se sirve en color negro, para otros acabados consultar al Departamento Comercial. Se ofrecen dos tamaños de caja diferentes y con conectividad configurable, acorde al siguiente esquema:

### Optional preinstalled wiring IN 0006

Preinstalled wiring consists in the addition of the necessary mechanisms to integrate power systems in the table, so that wiring is hidden until the way out in the floor.

Necessary grommet are included and 3m cable (from the power system). For other cable dimensions contact the Customer Department.

Tables with only one base are exempt of this charge, for the rest of tables ask the Customer Department.

### Preinstalación del cableado IN 0006

La preinstalación consiste en el montaje de los mecanismos necesarios para integrar el sistema de electrificación en la mesa, de modo que el cableado quede oculto hasta su salida por la base. Se incluyen los pasacables necesarios y 3 metros de cable (midiendo desde el sistema de conexiones).

Las mesas de una sola base quedan exentas de este cargo, para el resto consultar al Departamento Comercial.

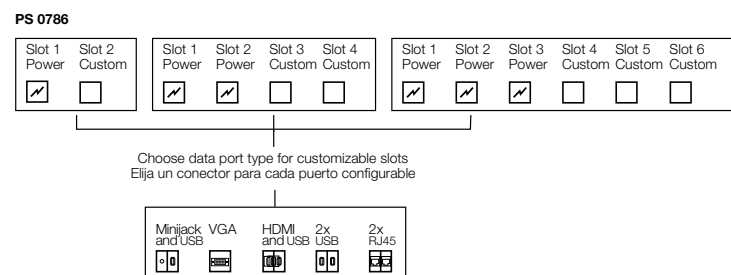
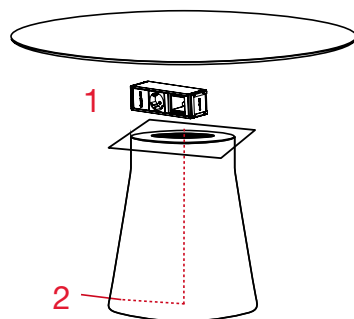

### 1 Power boxes distribution

By default, power system will be placed according to the image below.

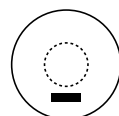

### Distribución de sistemas

De serie el sistema se dispondrá en la parte inferior del sobre, junto a la columna, tal y como puede apreciarse en el siguiente esquema.

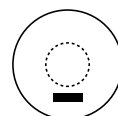

### 2 Wiring management

The cable way out can be performed directly from the power system or thru a canal in the base bottom, so that is hidden until it gets to the floor.

### Gestión del cableado

La salida del cable se realiza a través de la base, de modo que el cable queda oculto hasta llegar al suelo.





Materials / Materiales



The finishes and colors available for each collection can be found at the price list of Andreu World or at: [www.andreuworld.com](http://www.andreuworld.com)

Los acabados y colores disponibles de cada colección se pueden consultar en la tarifa de precios de Andreu World o en: [www.andreuworld.com](http://www.andreuworld.com)

### Wood / Maderas



**301**  
Natural beech  
Haya natural



**305**  
\* Ash or beech finishes  
Acabado sobre fresno o haya



**306**  
Natural oak  
Roble natural



**307**  
Pure oak  
Roble puro



**311**  
Clear beech  
Haya clara



**322**  
\* Beech or oak finishes  
Acabado sobre roble o haya.



**336**  
\* Beech or oak finishes  
Acabado sobre roble o haya.



**364**  
\* Beech or oak finishes  
Acabado sobre roble o haya.



**369**  
\* Beech or oak finishes  
Acabado sobre roble o haya.



**372**  
\* Beech or oak finishes  
Acabado sobre roble o haya.



**377**  
Natural walnut  
Nogal natural

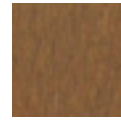

**378**  
\* Beech or oak finishes  
Acabado sobre roble o haya.



**381**  
\* Beech or oak finishes  
Acabado sobre roble o haya.

\* Estos acabados de color se pueden aplicar sobre madera maciza o chapa de haya o roble.  
\* These wood finishes are available on solid wood or oak and beech plywood.

### Premium finished and wood lacquers / Acabados premium y lacas madera



**641**  
White  
Blanca



**645L**  
NCS 2005-Y20R  
Sand  
Arena



**646L**  
NCS S 4005-Y20R  
Basalt grey  
Gris basalto



**642L**  
RAL 3013  
Cayenne red  
Rojo cayena



**380**  
Black  
Negro



**605L**  
NCS S 6502-B  
Dark grey  
Gris oscuro



**606L**  
RAL 1005  
Yellow mustard  
Amarillo mostaza



**661**  
Red  
Rojo



**601**  
Beech finish  
Acabado sobre haya



**610**  
Oak finish  
Acabado sobre roble

### Laminate finish / Acabado laminado



**L205**  
Oak  
Roble



**L204**  
Maple  
Arce



**L202**  
Walnut  
Nogal



**L203**  
Cherry  
Cerezo



**L206**  
Dark walnut  
Nogal oscuro



**L200**  
White  
Blanco



**L300**  
Sand  
Arena



**L302**  
Basalt grey  
Gris basalto



**L301**  
Dark grey  
Gris oscuro

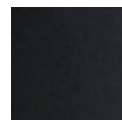

**L201**  
Black  
Negro

### Compacto HPL



**B200**  
White  
Blanco



**N201**  
Black  
Negro

### Linoleum / Linóleo



**L315**  
Ivory  
Marfil

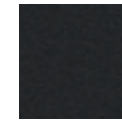

**L316**  
Black  
Negro

### Ultra-matte / Ultramate



**L310**  
White  
Blanco



**L311**  
Black  
Negro

### Dekton



**DKAR**  
Sand  
Arena

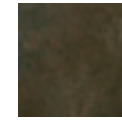

**DKMR**  
Earth Brown  
Marrón Tierra



**DKRC**  
Rock Grey  
Gris Roca



**DKNG**  
Black  
Negro

### Technical Stone / Cerámica

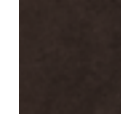

**CEMT**  
Earth brown  
Marrón tierra

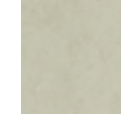

**CEGA**  
Sand grey  
Gris arena

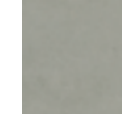

**CEGP**  
Stone grey  
Gris piedra

### Marble / Mármol

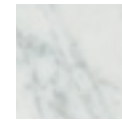

Carrara



Calacatta

### Cement / Cemento



Cement  
Cemento

### Solid Surface



Gracier white  
Blanco glaciar

### Glass / Cristal



**6000**  
RAL 9003  
White  
Blanco



**6002**  
NCS 2005-Y20R  
Sand  
Arena



**6012**  
NCS S 4005-Y20R  
Basalt Grey  
Gris Basalto



**6003**  
Ral 3013  
Cayenne Red  
Rojo Cayena



**6006**  
RAL 9005  
Black  
Negro



**6013**  
NCS S 6502-B  
Dark Grey  
Gris Oscuro



**6013**  
NCS S 6502-B  
Dark Grey  
Gris Oscuro

### Thermo-polymer / Termopolímero



**6000**  
RAL 9003  
White  
Blanco



**6002**  
NCS 2005-Y20R  
Sand  
Arena



**6012**  
NCS S 4005-Y20R  
Basalt grey  
Gris basalto



**6003**  
RAL 3013  
Cayenne red  
Rojo cayena



**6006**  
RAL 9005  
Black  
Negro



**6013**  
NCS S 6502-B  
Dark Grey  
Gris oscuro



**6014**  
NCS S 3050-G60Y  
Mango Green  
Verde Mango



**6015**  
NCS 4020-Y20R  
Camel brown  
Marrón camel



**6016**  
Pantone 5445U  
Water blue  
Azul agua



**6017**  
Pantone 5655U  
Marine green  
Verde marina



**6018**  
Pantone 7526U  
Terracotta brown  
Marrón terracota



**6019**  
RAL 3009  
Oxide red  
Rojo Óxido



The finishes and colors available for each collection can be found at the price list of Andreu World or at: [www.andreuworld.com](http://www.andreuworld.com)

Los acabados y colores disponibles de cada colección se pueden consultar en la tarifa de precios de Andreu World o en: [www.andreuworld.com](http://www.andreuworld.com)

### Steel EPL 5 / Acero EPL 5

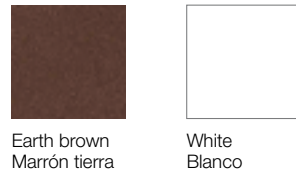

### Steel / Acero

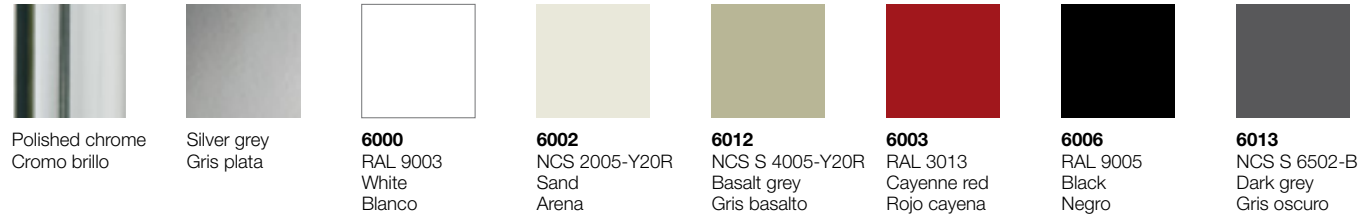

### Aluminum / Aluminio

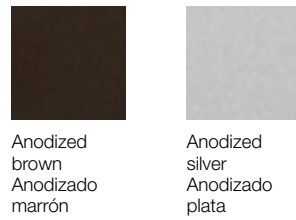

### Cord / Cuerda

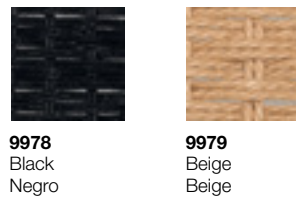

### Woven bands / Cincha

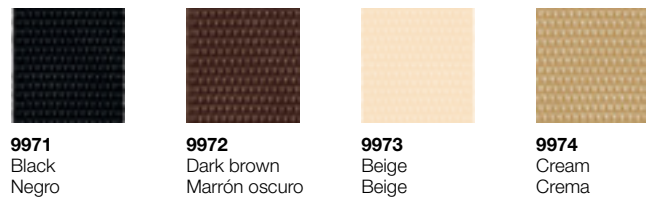



## Andreu World Leather

### Leather Piel / Cat. L1

Composition / Composición  
First categorie cow leather  
Piel de vaca de 1ª categoría

Not suitable for loose cover. Dry  
cleaning recommended.  
No válido para funda. Se  
recomienda su lavado en seco.

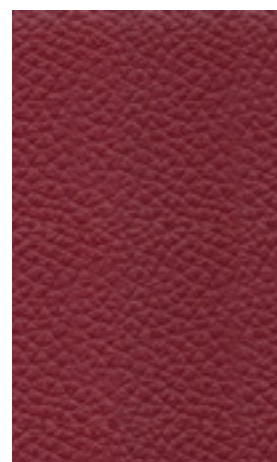

4210



4025

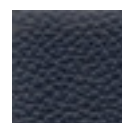

4029



4034

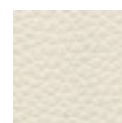

4035

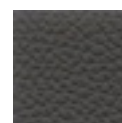

4047



4075



4076



4077

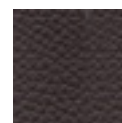

4084

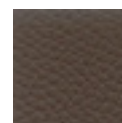

4085



4224



4225

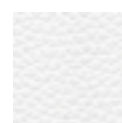

4226

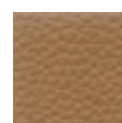

4228

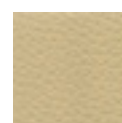

4229

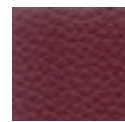

4231



4232



4234



4235



4236

### Hide Leather Cuero / Cat. L2

Composition / Composición  
Chrome tanned split leather.  
Base in polyurethane resin  
emulsion in water. Cellulose  
nitric varnish.  
Costra cocida al cromo. Base  
de emulsiones de resinas  
poliuretánicas en agua. Barniz  
nitro celulósico.

Not suitable for loose cover. Dry  
cleaning recommended.  
No válido para funda. Se  
recomienda su lavado en seco.

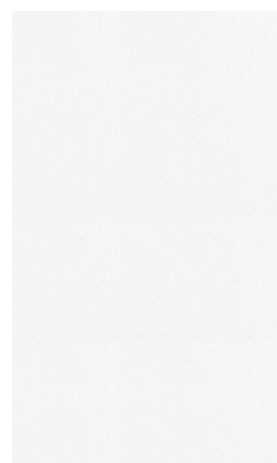

4050



4051



4052



4053



4054

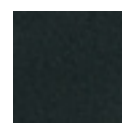

4055



4056



4057



4058



4061

## Andreu World Leather

### Leather Piel / Cat. L3

Composition / Composición  
Polished full grain leather  
Plena flor pulida

The leathers have passed  
comprehensive processes of  
classification and treatment. The  
naturalness makes the texture  
appreciated from the marks and  
irregularities of the leather.  
Las pieles han pasado exhaustivos  
procesos de clasificación y  
tratamiento. La naturalidad hace  
que en su textura se aprecien  
ciertas marcas e irregularidades  
propias de la piel.

Not suitable for loose cover. Dry  
cleaning recommended.  
No válido para funda. Se  
recomienda su lavado en seco.



1800

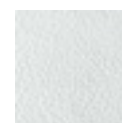

1801

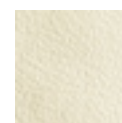

1802



1803



1804



1805



1806



1809



1810



1811



1812



1813

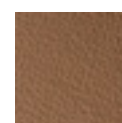

1815



1816

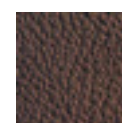

1818



1819

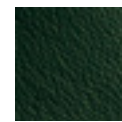

1820

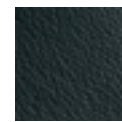

1821



1822



1823



1824



## Andreu World Textiles

### Microfibra Microfibre / Cat. 1

Composition / Composición  
Surface / Superficie 100% Pol.  
Backing / Soporte 67% Pol. 33%  
CO

Martindale test /  
Resistencia a la abrasión  
> 40.000 Cycles / Ciclos (BS  
5690:91)

Not suitable for loose cover. Dry  
cleaning recommended.  
No válido para funda. Se  
recomienda su lavado en seco.

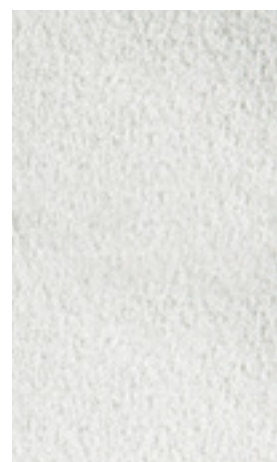

1500



1501



1502



1503



1504

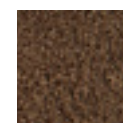

1505



1507



1508



1510



1511



1512

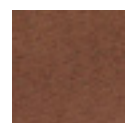

1514



1515



1516

### Jacquard One / Cat. 1

Composition / Composición  
48% PP. 33% PES. 19% CO.

Martindale test /  
Resistencia a la abrasión  
> 31.000 Cycles / Ciclos  
(EN ISO 12947-2 min. 20.000)

Suitable for loose cover. Dry  
cleaning recommended.  
Válido para funda. Se recomienda  
su lavado en seco.



1721

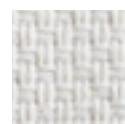

1714

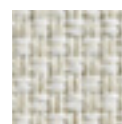

1715

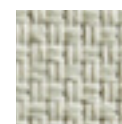

1716

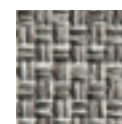

1717

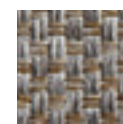

1718

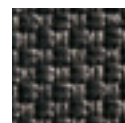

1722



1723



1726



1727

## Andreu World Textiles

### Jacquard Three / Cat. 1

Composition / Composición  
50% PP. 31% PE. 19% CO

Martindale test /  
Resistencia a la abrasión  
32.500 Cycles / Ciclos  
(EN ISO 12947-2:1998)

Suitable for loose cover. Dry  
cleaning recommended.  
Válido para funda. Se recomienda  
su lavado en seco.

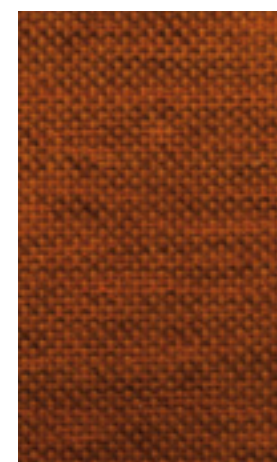

1746

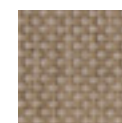

1740

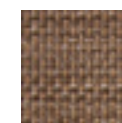

1741

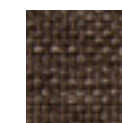

1742

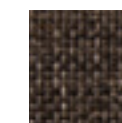

1743



1744

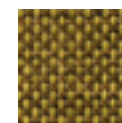

1745

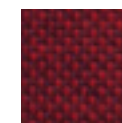

1747



1749



1750



1751

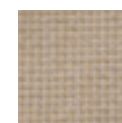

1752

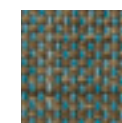

1754



1755

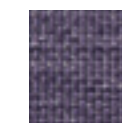

1756

### Valencia / Cat. 1

Composition / Composición  
100% Vinyl

Martindale test /  
Resistencia a la abrasión  
300.000 Cycles / Ciclos

No suitable for loose cover. Dry  
cleaning recommended.  
No válido para funda. Se  
recomienda su lavado en seco.

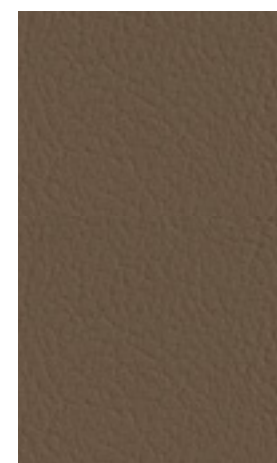

107-0034  
Taupe

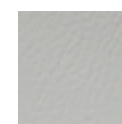

107-9486  
Pure-White

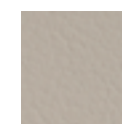

107-8032  
Weiss



107-1049  
Leinen

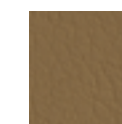

107-1050  
Beige

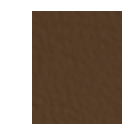

107-9001  
Sumatra

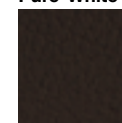

107-4041  
Meteor



107-6013  
Melone

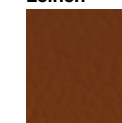

107-0035  
Terracotta

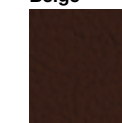

107-0033  
Buche

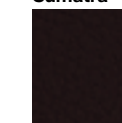

107-0020  
Mocca

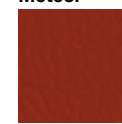

107-6003  
Nectarine

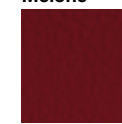

107-2074  
Kirsche

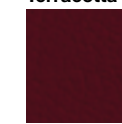

107-2062  
Port



107-3068  
Marine

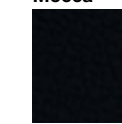

107-9035  
Schwarz



## Andreu World Textiles

### Era / Grade 1

Composition / Composición  
100% Polyester  
100% Poliéster

Martindale test /  
Resistencia a la abrasión  
>50.000 Cycles / Ciclos

Suitable for loose cover.  
Válido para funda.



### Urban / Grade 1

Composition / Composición  
100% Polyester  
100% Poliéster

Martindale test /  
Resistencia a la abrasión  
100.000 Cycles / Ciclos

Suitable for loose cover.  
Válido para funda.



## Andreu World Textiles

### Rivet / Grade 1

Composition / Composición  
100% Repreve Recycled  
100% Repreve Reciclado

Martindale test /  
Resistencia a la abrasión  
>50.000 Cycles / Ciclos

Suitable for loose cover.  
Válido para funda.

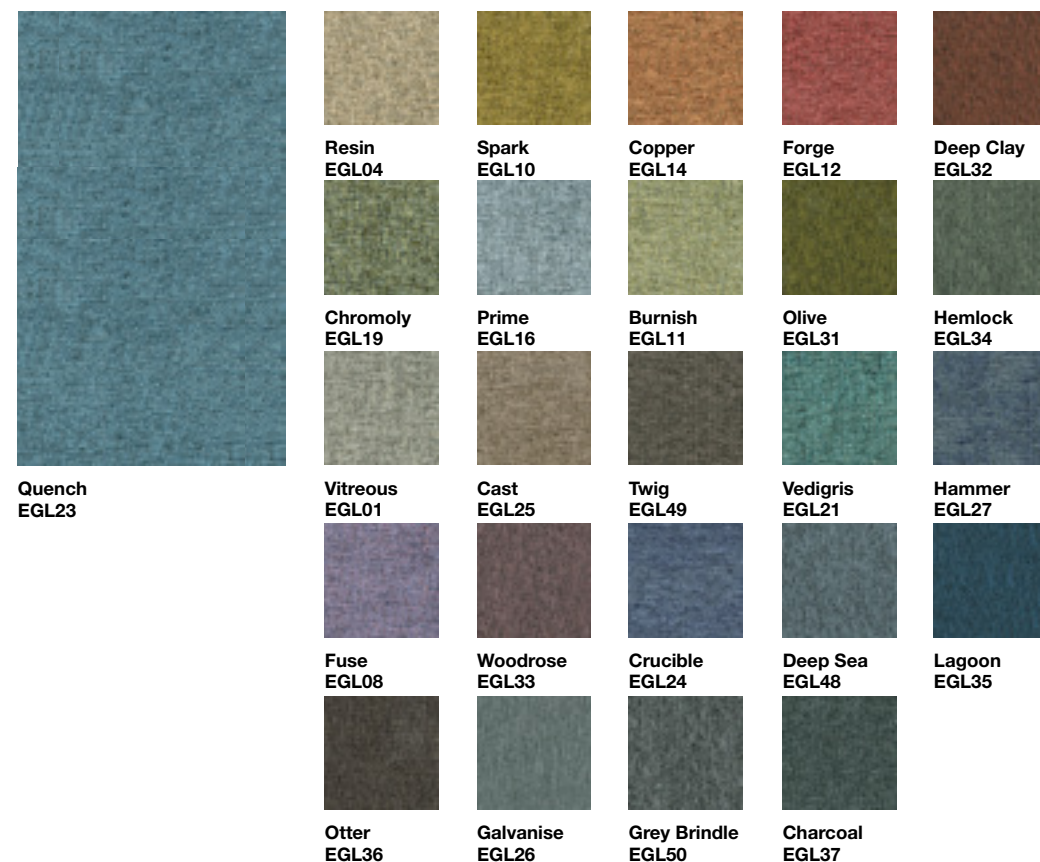



## Andreu World Textiles

### Jacquard Two / Cat. 2

Composition / Composición  
89% PES. 11% CO.

Martindale test /  
Resistencia a la abrasión  
> 60.000 Cycles / Ciclos  
(EN ISO 12947-2 min. 20.000)

Suitable for loose cover. Dry  
cleaning recommended.  
Válido para funda. Se recomienda  
su lavado en seco.



1709

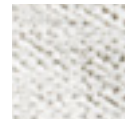

1700

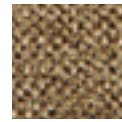

1701



1702

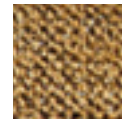

1703

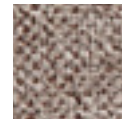

1704



1705



1706

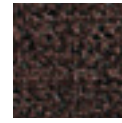

1707

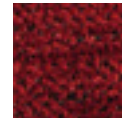

1711



1712



1713

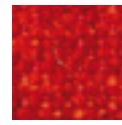

1730

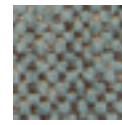

1731

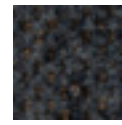

1732

### Jacquard Four / Cat. 3

Composition / Composición  
34% WO. 28% PES. 23% PP.  
15%CO

Martindale test /  
Resistencia a la abrasión  
62.000 Cycles / Ciclos  
(EN ISO 12947/2)

Not suitable for loose cover. Dry  
cleaning recommended.  
No válido para funda. Se  
recomienda su lavado en seco.



2256



2250



2251



2252



2253



2254



2255



2257



2258



2259



2260



2261



2262



2263



2264

## Andreu World Textiles

### Jacquard Four / Cat. 4 Special for Nuez Collection

Composition / Composición  
34% WO. 28% PES. 23% PP.  
15%CO

Martindale test /  
Resistencia a la abrasión  
62.000 Cycles / Ciclos  
(EN ISO 12947/2)

Not suitable for loose cover. Dry  
cleaning recommended.  
No válido para funda. Se  
recomienda su lavado en seco.



2267



2265



2266



2268



2269



2270

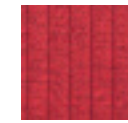

2271



2272



2273



2274



2275



2276



2277



2278



2279

### Dolce / Cat. 4

Composition / Composición  
100% Polyurethane

Martindale test /  
Resistencia a la abrasión  
300.000 Cycles / Ciclos

Not suitable for loose cover. Dry  
cleaning recommended.  
No válido para funda. Se  
recomienda su lavado en seco.

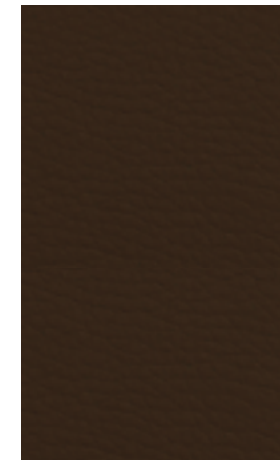

DOL-6712  
Mocha

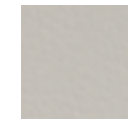

DOL-6701  
White



DOL-6702  
Ivory



DOL-6704  
Dune



DOL-6705  
Sand



DOL-6708  
Mushroom



DOL-6709  
Camel



DOL-6711  
Russel



DOL-6713  
Chocolate



DOL-6718  
Tangelo



DOL-6719  
Poppy



DOL-6714  
Burgundy



DOL-6725  
Indigo



DOL-6727  
Meteor



DOL-6728  
Black



## Kvadrat Textiles / Telas Kvadrat

Revive 1 / Grade 3

Composition / Composición  
100% Recycled Polyester FR  
100% Poliéster reciclado FR

Martindale test /  
Resistencia a la abrasión  
60.000 Cycles / Ciclos

Not suitable for loose cover.  
No válido para funda.



## Kvadrat Textiles / Telas Kvadrat

Cava 3 / Grade 4

Composition / Composición  
90% Wool 10% Nylon  
90% Lana 10% Nylon

Martindale test /  
Resistencia a la abrasión  
80.000 Cycles / Ciclos

Not suitable for loose cover.  
No válido para funda.

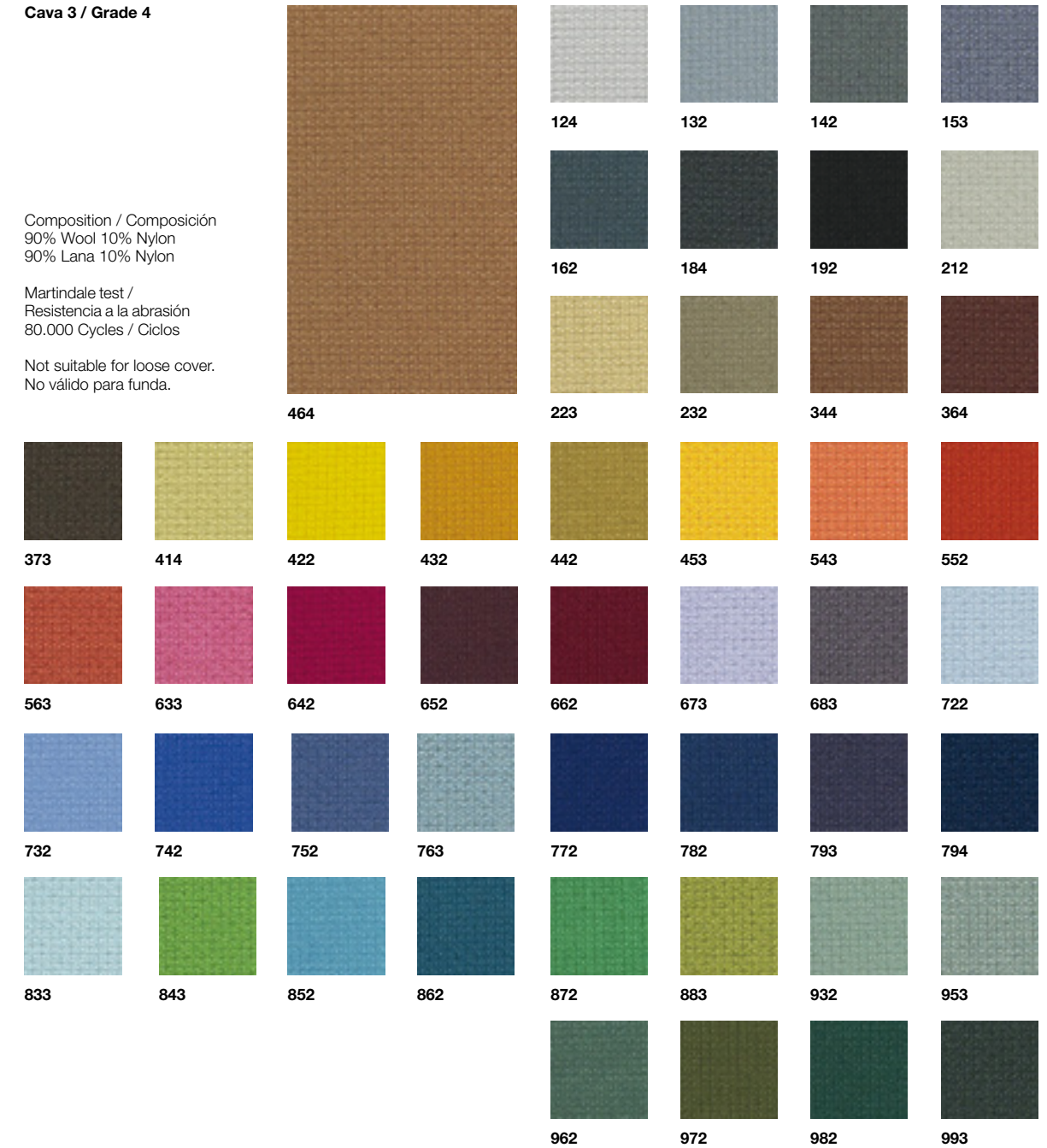



## Kvadrat Textiles / Telas Kvadrat

### Field / Grade 4

Composition / Composición  
100% Trevira

Martindale test /  
Resistencia a la abrasión  
100.000 Cycles / Ciclos

Not suitable for loose cover.  
No válido para funda.

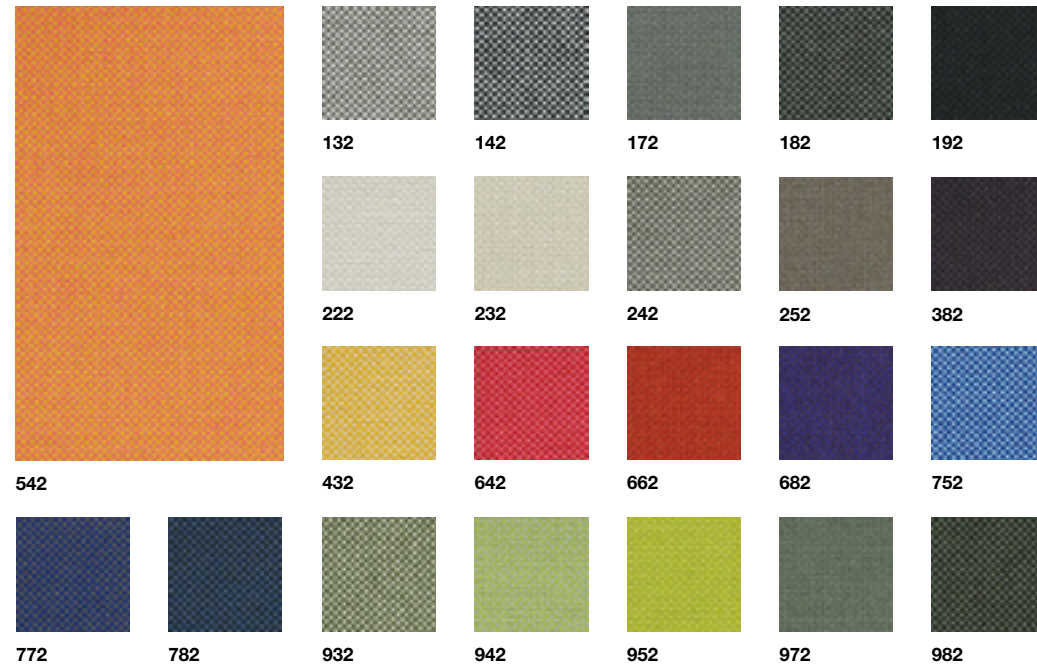

### Floyd / Grade 4

Composition / Composición  
50% Polyester- 45%New Wool  
worsted - 5%Nylon  
50% Poliéster- 45%Nueva lana  
peinada - 5%Nylon

Martindale test /  
Resistencia a la abrasión  
50.000 Cycles / Ciclos

Not suitable for loose cover.  
No válido para funda.

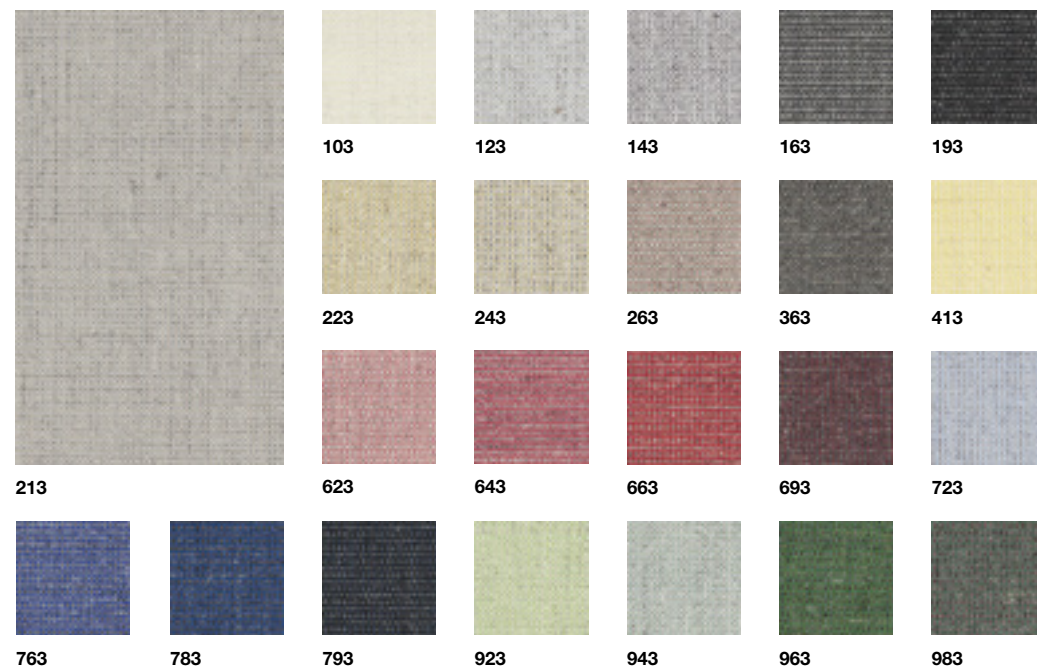

## Kvadrat Textiles / Telas Kvadrat

### Remix 2 / Grade 4

Composition / Composición  
90% Wool 10% Nylon  
90% Lana 10% Nylon

Martindale test /  
Resistencia a la abrasión  
100.000 Cycles / Ciclos

Not suitable for loose cover.  
No válido para funda.

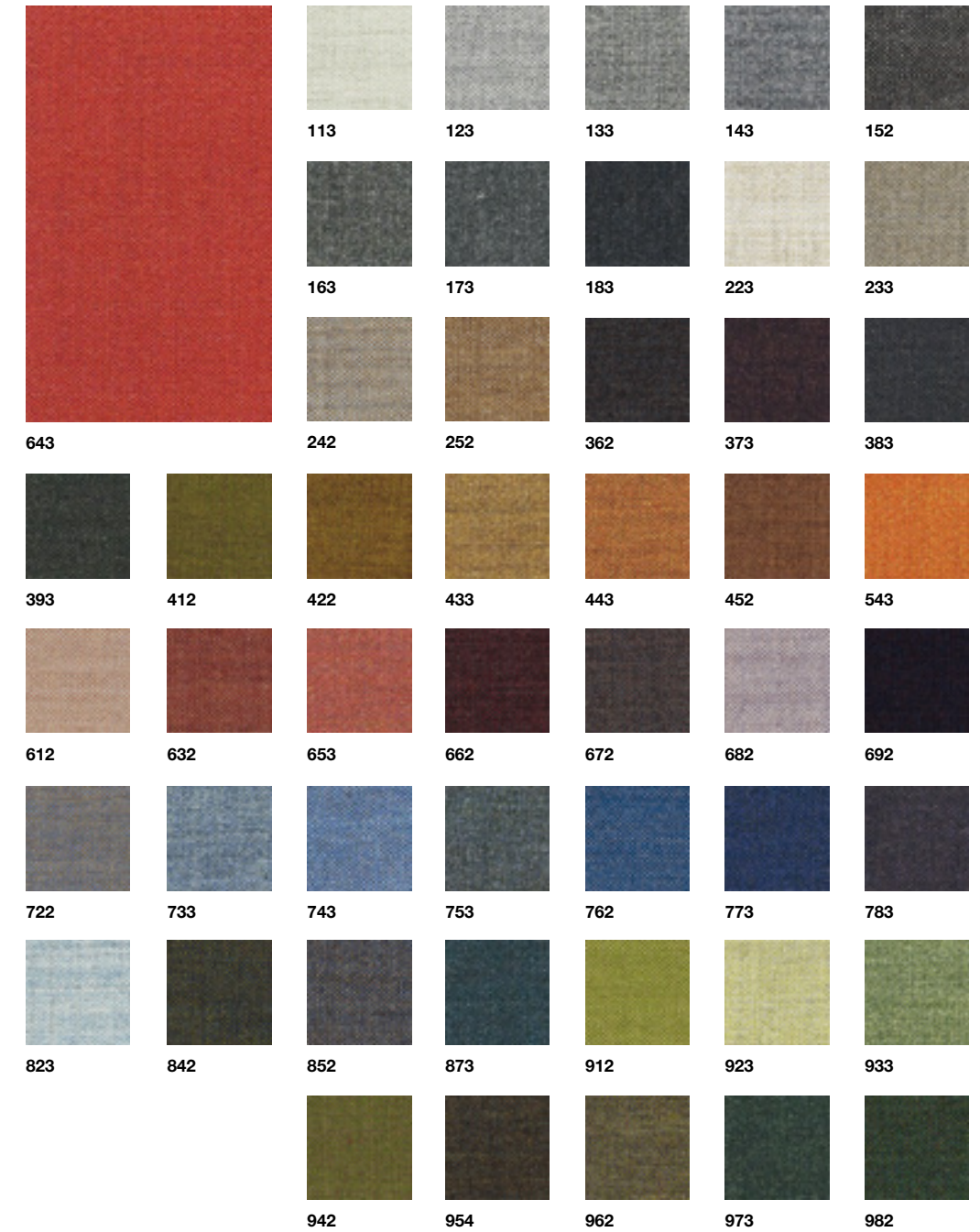



## Kvadrat Textiles / Telas Kvadrat

Ledger / Grade 5

Composition / Composición  
100% Polyurethane  
100% Poliuretano

Martindale test /  
Resistencia a la abrasión  
> 100.000 Cycles / Ciclos

Not suitable for loose cover.  
No válido para funda.



## Kvadrat Textiles / Telas Kvadrat

Messenger 4 / Grade 5

Composition / Composición  
78% Post. industrial recycled  
polyester 15% Polyester 7% Nylon  
78% Poliéster reciclado 15%  
Poliéster 7% Nylon

Martindale test /  
Resistencia a la abrasión  
65.000 Cycles / Ciclos

Suitable for loose cover.  
Válido para funda.





## Kvadrat Textiles / Telas Kvadrat

Clara 2 / Grade 6

Composition / Composición  
92% Wool 8% Nylon  
92% Lana 8% Nylon

Martindale test /  
Resistencia a la abrasión  
80.000 Cycles / Ciclos

Not suitable for loose cover.  
No válido para funda.

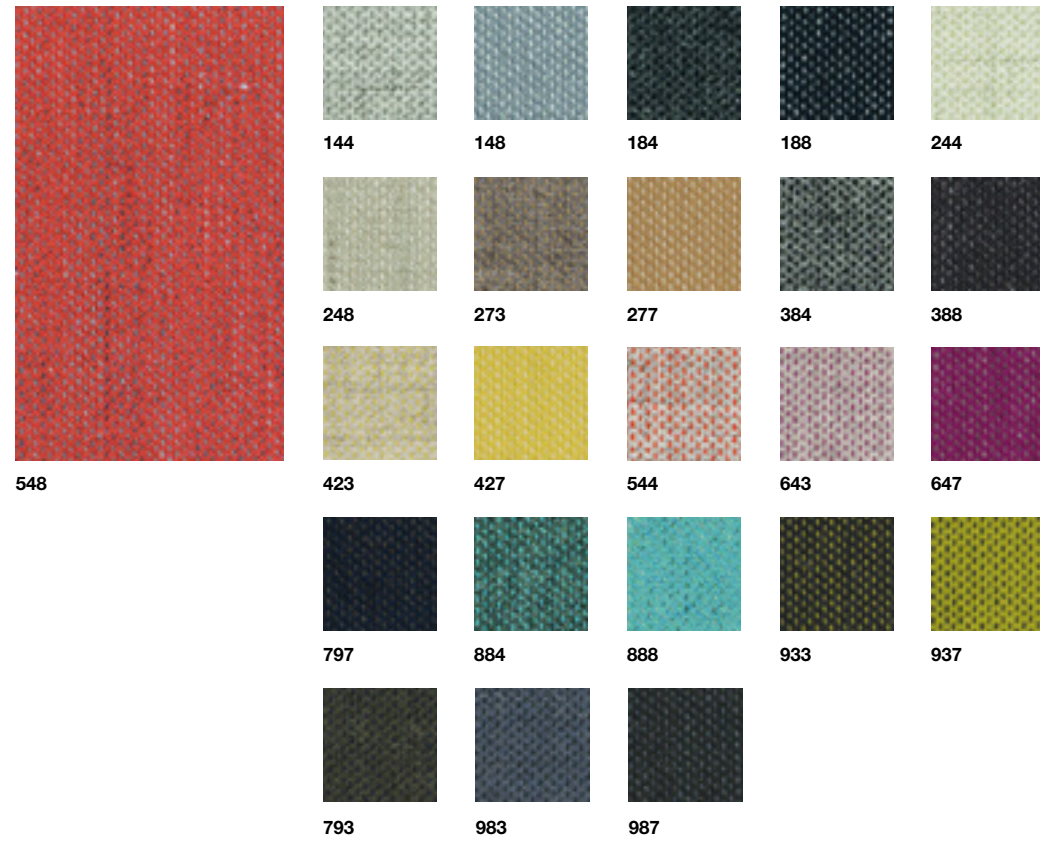

## Kvadrat Textiles / Telas Kvadrat

Canvas 2 / Grade 7

Composition / Composición  
90% New wool worsted -  
10% Nylon  
90% Nueva lana peinada -  
10% Nylon

Martindale test /  
Resistencia a la abrasión  
100.000 Cycles / Ciclos

Suitable for loose cover.  
Válido para funda.





## Kvadrat Textiles / Telas Kvadrat

Rime / Grade 7

Composition / Composición  
90% Wool 10% Nylon  
90% Lana 10% Nylon

Martindale test /  
Resistencia a la abrasión  
100.000 Cycles / Ciclos

Not suitable for loose cover.  
No válido para funda.



## Kvadrat Textiles / Telas Kvadrat

Sudden / Grade 7

Composition / Composición  
100% Polyurethane  
100% Poliuretano

Martindale test /  
Resistencia a la abrasión  
> 100.000 Cycles / Ciclos

Not suitable for loose cover.  
No válido para funda.





## Kvadrat Textiles / Telas Kvadrat

Divina 3 / Grade 8

Composition / Composición  
100% Wool  
100% Lana

Martindale test /  
Resistencia a la abrasión  
45.000 Cycles / Ciclos

Suitable for loose cover.  
Válido para funda.



## Kvadrat Textiles / Telas Kvadrat

Fiord / Grade 8

Composition / Composición  
92% New wool worsted 8% Nylon  
92% Nueva lana peinada 8%Nylon

Martindale test /  
Resistencia a la abrasión  
60.000 Cycles / Ciclos

Not suitable for loose cover.  
No válido para funda.

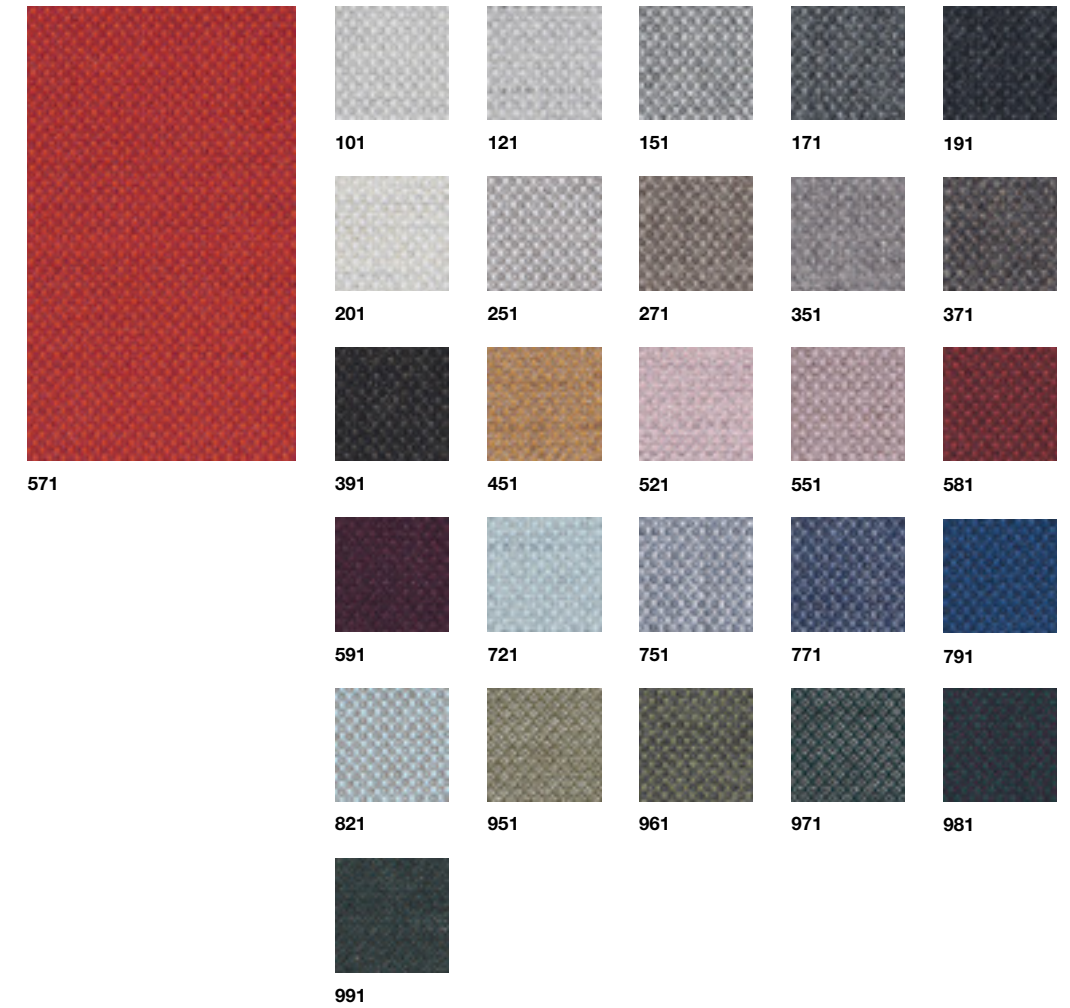



## Kvadrat Textiles / Telas Kvadrat

Harald 3 / Grade 8

Composition / Composición  
100% Cotton  
100% Algodón

Martindale test /  
Resistencia a la abrasión  
100.000 Cycles / Ciclos

Not suitable for loose cover.  
No válido para funda.



## Kvadrat Textiles / Telas Kvadrat

Tonus 4 / Grade 8

Composition / Composición  
90% Wool 10% Helanca  
90% Lana 10% Helanca

Martindale test /  
Resistencia a la abrasión  
> 50.000 Cycles / Ciclos

Not suitable for loose cover.  
No válido para funda.





## Kvadrat Textiles / Telas Kvadrat

Tonus Meadow / Grade 8

Composition / Composición  
90% Wool 10% Helanca  
90% Lana 10% Helanca

Martindale test /  
Resistencia a la abrasión  
100.000 Cycles / Ciclos

Not suitable for loose cover.  
No válido para funda.

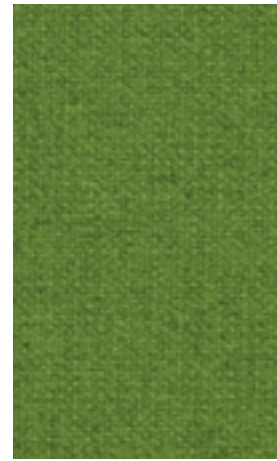

975



115



116

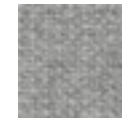

125



126



165



166



225



226



265



266



445



446



465



466

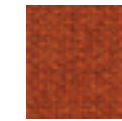

575



576



675



676

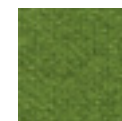

## Kvadrat Textiles / Telas Kvadrat

Divina Melange 2 / Grade 9

Composition / Composición  
100% Wool  
100% Lana

Martindale test /  
Resistencia a la abrasión  
45.000 Cycles / Ciclos

Suitable for loose cover.  
Válido para funda.



531



120



170

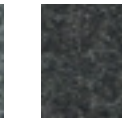

180

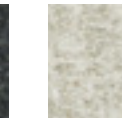

220

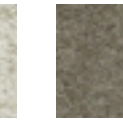

260



280



421



471

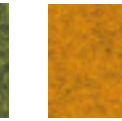

521



571

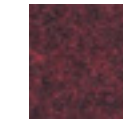

581



620



631



671



681



721

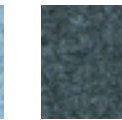

771

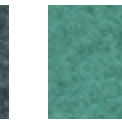

821



871



920



931



971



## Kvadrat Textiles / Telas Kvadrat

Divina MD / Grade 9

Composition / Composición  
100% Wool  
100% Lana

Martindale test /  
Resistencia a la abrasión  
45.000 Cycles / Ciclos

Suitable for loose cover.  
Válido para funda.

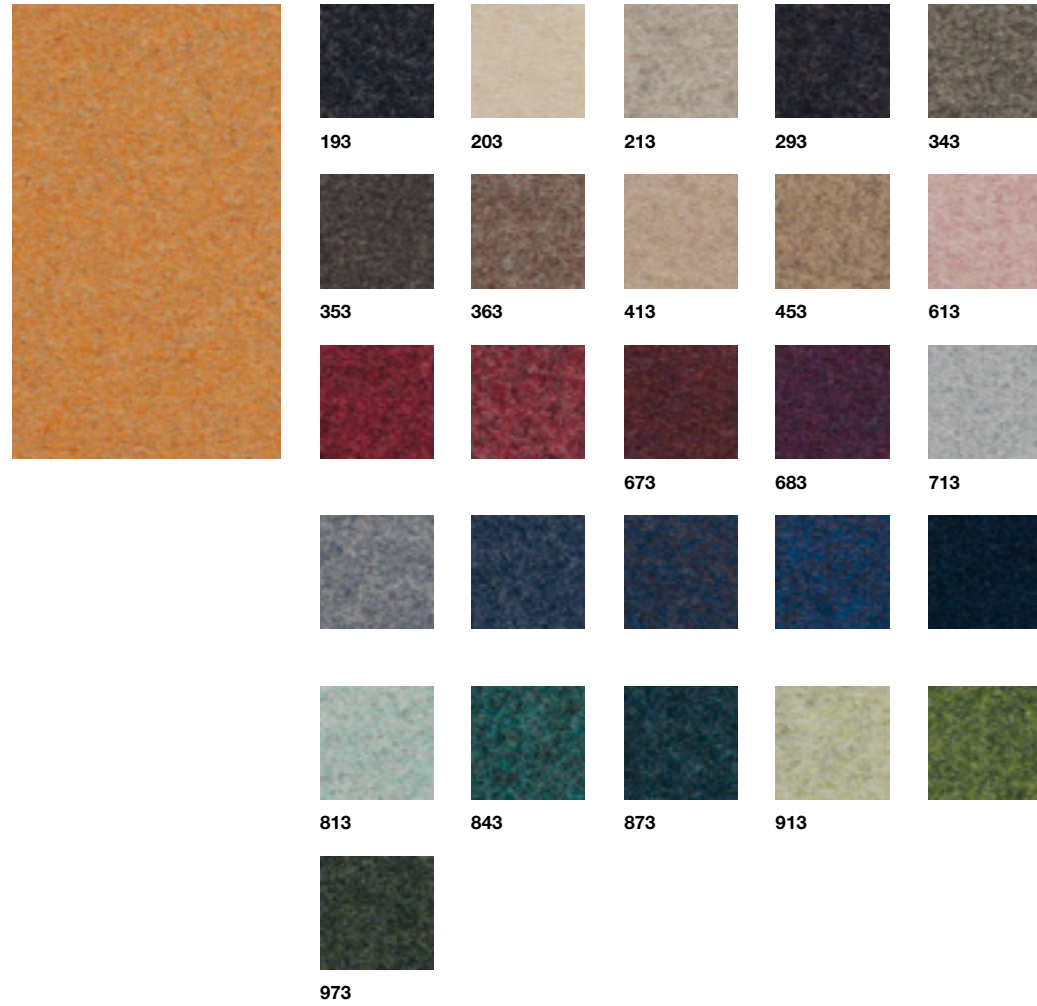

## Kvadrat Textiles / Telas Kvadrat

Hallingdal 65 / Grade 9

Composition / Composición  
70% Wool 30% Viscose  
70% Lana 30% Viscosa

Martindale test /  
Resistencia a la abrasión  
100.000 Cycles / Ciclos

Not suitable for loose cover.  
No válido para funda.

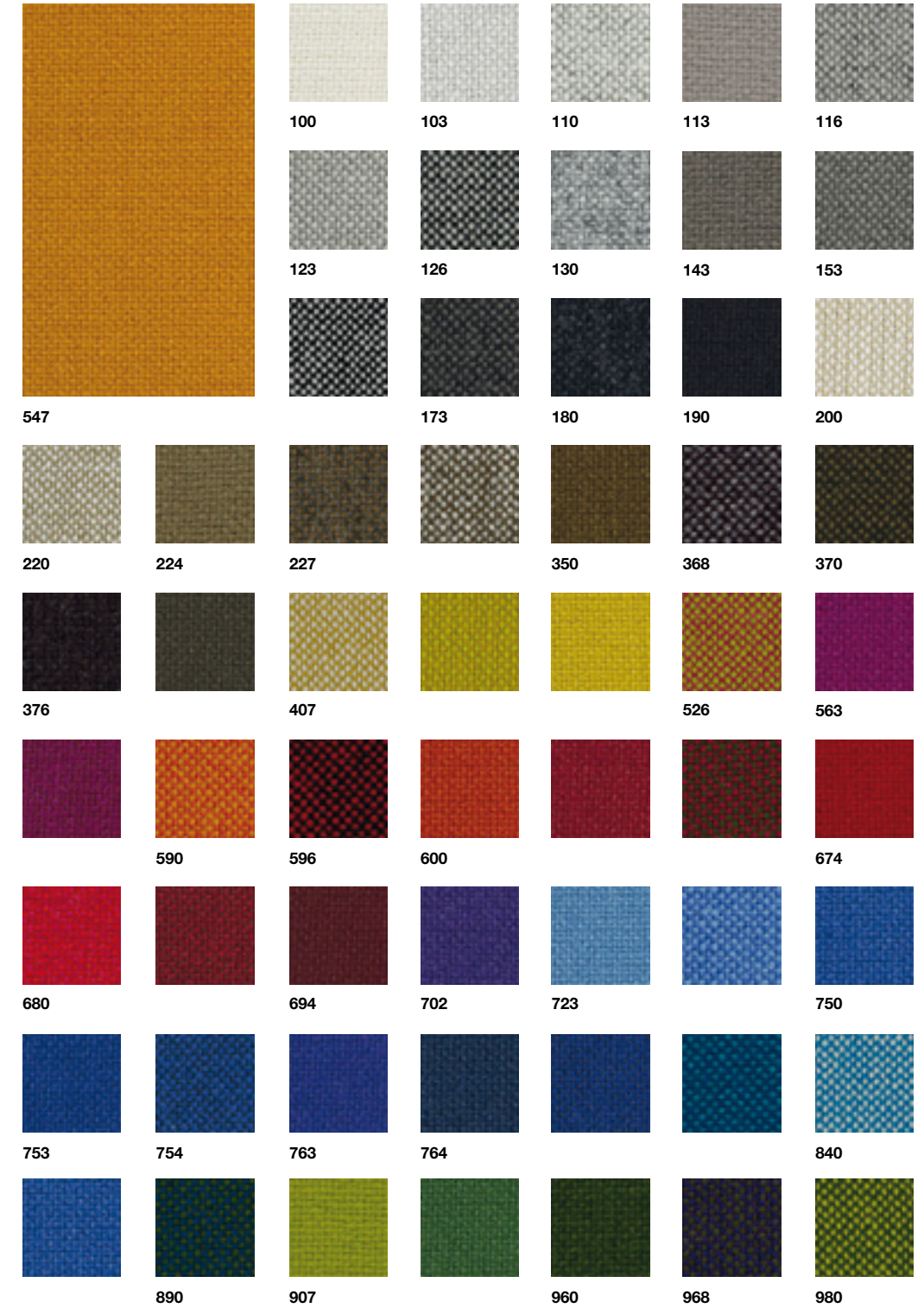



## Kvadrat Textiles / Telas Kvadrat

Composition / Composición  
90% Wool 10% Nylon  
90% Lana 10% Nylon

Martindale test /  
Resistencia a la abrasión  
80.000 Cycles / Ciclos

Suitable for loose cover.  
Válido para funda.

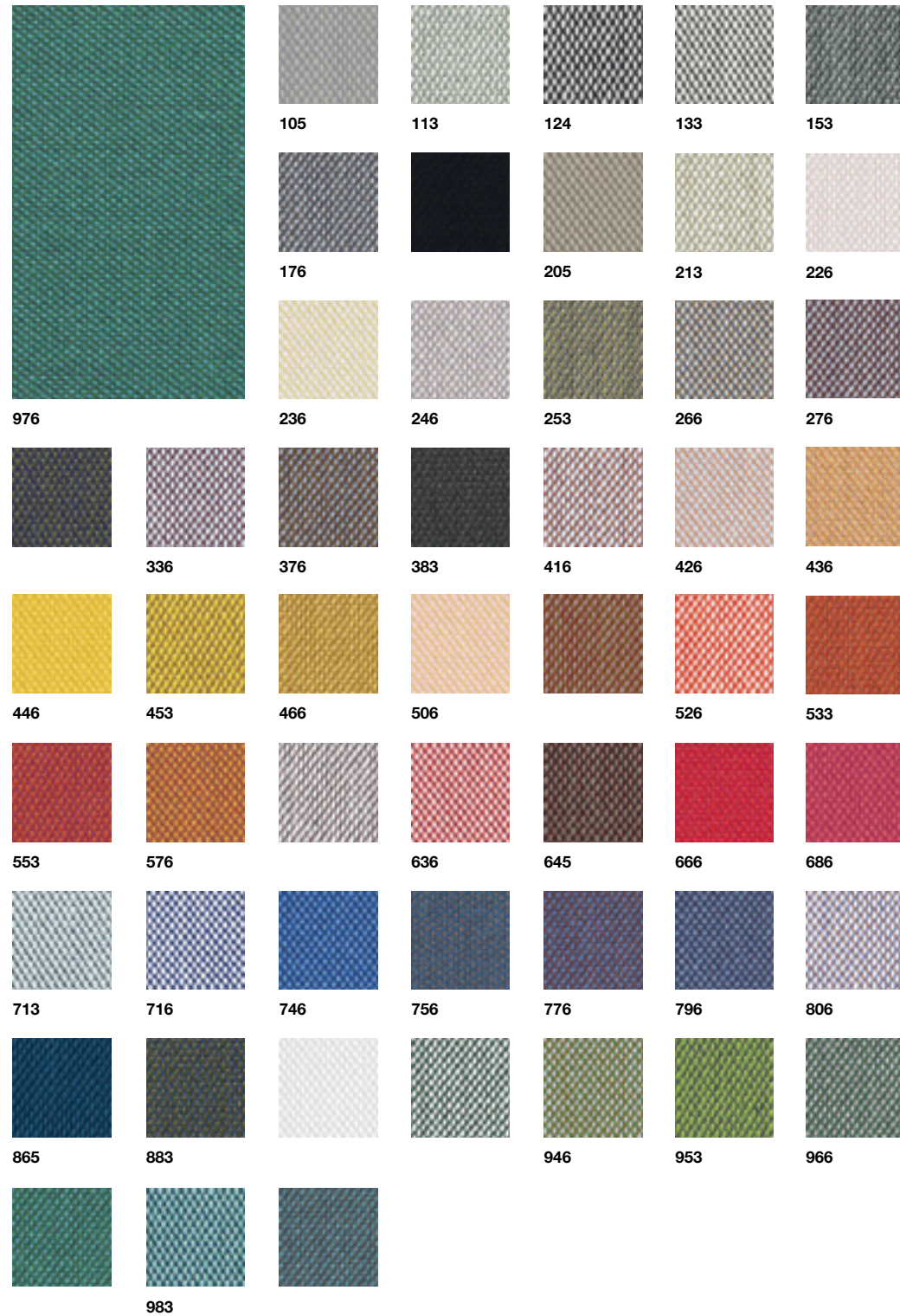

## Camira Textiles / Telas Camira

Citadel / Grade 1

Composition / Composición  
100% Flame Retardant  
Polypropylene  
100% Polipropileno resistente al  
fuego

Martindale test /  
Resistencia a la abrasión  
>30.000 Cycles / Ciclos

Suitable for loose cover.  
Válido para funda.





**Camira Textiles / Telas Camira**

Composition / Composición  
30%Flax - 70% Virgin wool  
30%Lino - 70%Lana virgen

Martindale test /  
Resistencia a la abrasión  
>50.000 Cycles / Ciclos

Suitable for loose cover.  
Válido para funda.

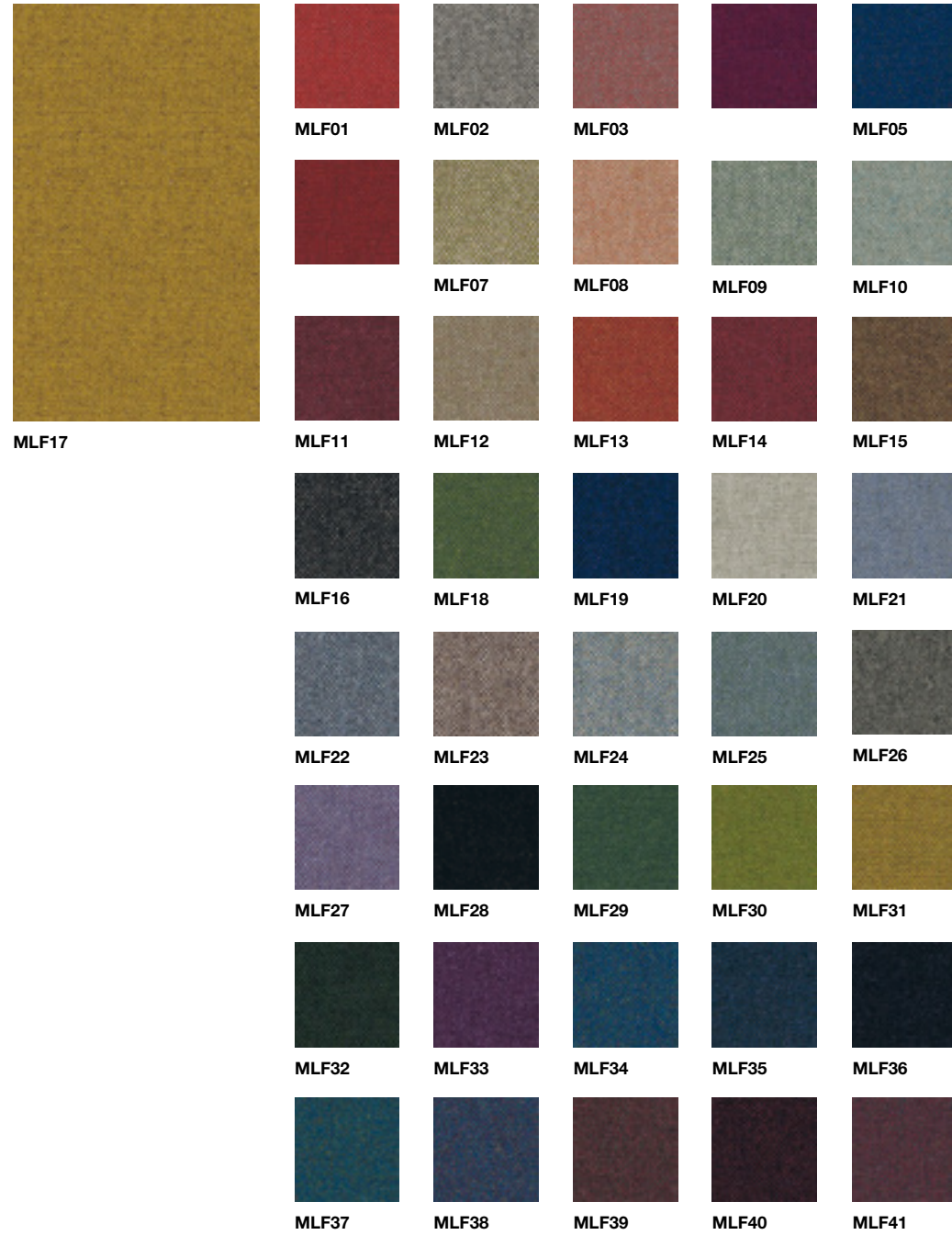

**Camira Textiles / Telas Camira**

Nexus / Grade 4

Composition / Composición  
100% Polyester  
100% Poliéster

Martindale test /  
Resistencia a la abrasión  
>100.000 Cycles / Ciclos

Suitable for loose cover.  
Válido para funda.



Hemp / Grade 4

Composition / Composición  
60% Virgin wool- 40%True Hemp  
60% Lana virgen- 40%Verdadero  
cañamo

Martindale test  
Resistencia a la abrasión /  
>40.000 Cycles / Ciclos

Suitable for loose cover.  
Válido para funda.





## Camira Textiles / Telas Camira

Oxygen / Grade 4

Composition / Composición  
90% Virgin wool-10% Polyamide  
90% Lana virgen-10% Poliamida

Martindale test /  
Resistencia a la abrasión  
>100.000 Cycles / Ciclos

Suitable for loose cover.  
Válido para funda.



## Camira Textiles / Telas Camira

Blazer / Grade 5

Composition / Composición  
100% Virgin wool  
100% Lana virgen

Martindale test  
Resistencia a la abrasión /  
> 50.000 Cycles / Ciclos

Suitable for loose cover.  
Válido para funda.





## Camira Textiles / Telas Camira

Silk / Grade 5

Composition / Composición  
67% Wool/22% Flax/11%Silk  
67%Lana/22%Flax/11%Seda

Martindale test /  
Resistencia a la abrasión  
>50.000 Cycles / Ciclos

Suitable for loose cover.  
Válido para funda.



SLK14

Sinergy / Grade 5

Composition / Composición  
90% New wool worsted -  
10%Nylon  
90% Nueva lana peinada - 10%  
Nylon

Martindale test  
Resistencia a la abrasión /  
100.000 Cycles / Ciclos

Suitable for loose cover.  
Válido para funda.



LDS05

## Camira Textiles / Telas Camira

Sinergy / Grade 5





## Camira Textiles / Telas Camira

Craggan / Grade 6

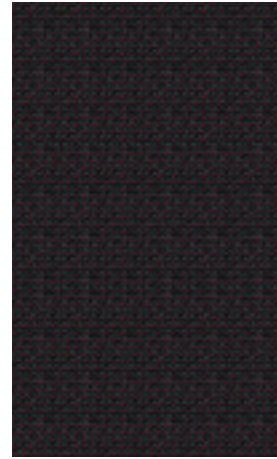

ZAN01



ZAN02

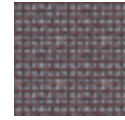

ZAN03

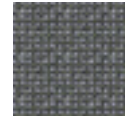

ZAN04



ZAN05



ZAN06



ZAN07



ZAN08

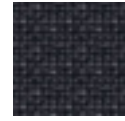

ZAN09

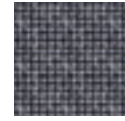

ZAN10

Composition / Composición  
100% Virgin wool  
100% Lana virgen

Martindale test /  
Resistencia a la abrasión  
>50.000 Cycles / Ciclos

Not suitable for loose cover.  
No válido para funda.

## Gabriel Textiles / Telas Gabriel

Medley / Grade 3



61003



60003

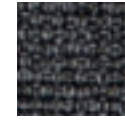

60004



60167



60999



61002



61004



61189

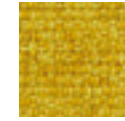

62002



62054

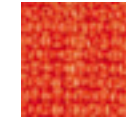

63013

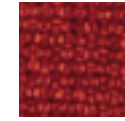

63016

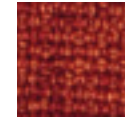

63017

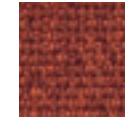

63063

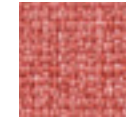

63064



64019

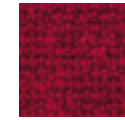

64123



64124



64125



65011

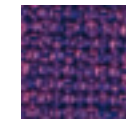

65012



65086



66007

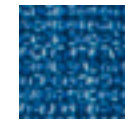

66009



66008



66010



66144



66145



67002

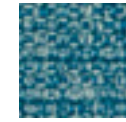

67006



67052



67053



67054



68002



68005



68114

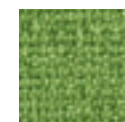

68115

Composition / Composición  
100% Polyester  
100% Poliéster

Martindale test /  
Resistencia a la abrasión  
75.000 Cycles / Ciclos

Suitable for loose cover.  
Válido para funda.



## Gabriel Textiles / Telas Gabriel

Step / Grade 5

Composition / Composición  
100% Trevira cs

Martindale test /  
Resistencia a la abrasión  
100.000 Cycles / Ciclos

Suitable for loose cover.  
Válido para funda.



## Gabriel Textiles / Telas Gabriel

Step Melange / Grade 5

Composition / Composición  
100% Trevira cs

Martindale test /  
Resistencia a la abrasión  
100.000 Cycles / Ciclos

Suitable for loose cover.  
Válido para funda.

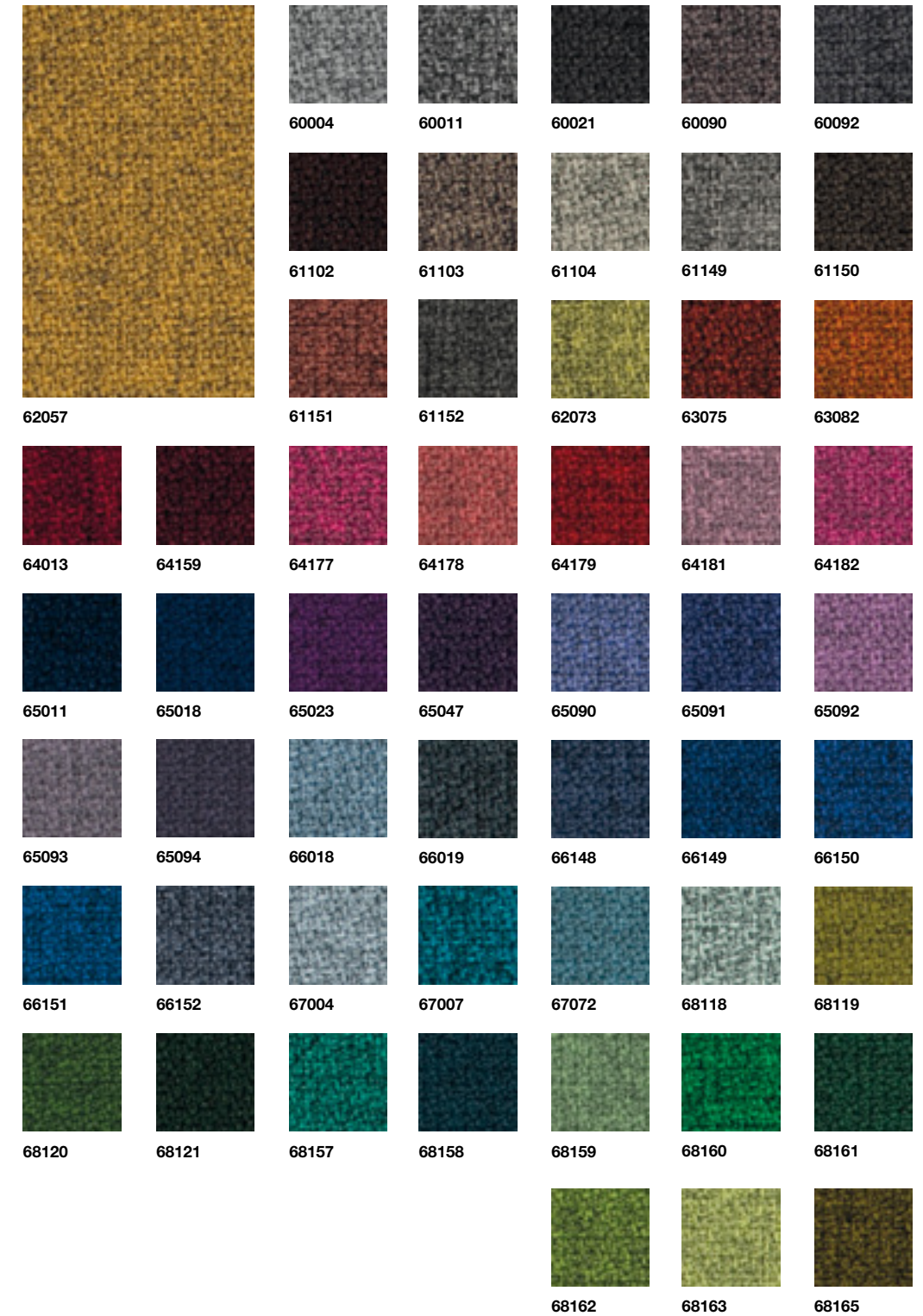



**Gabriel Textiles / Telas Gabriel**

Go Check / Grade 6

Composition / Composición  
100% Trevira cs

Martindale test /  
Resistencia a la abrasión  
80.000 Cycles / Ciclos

Not suitable for loose cover.  
No válido para funda.

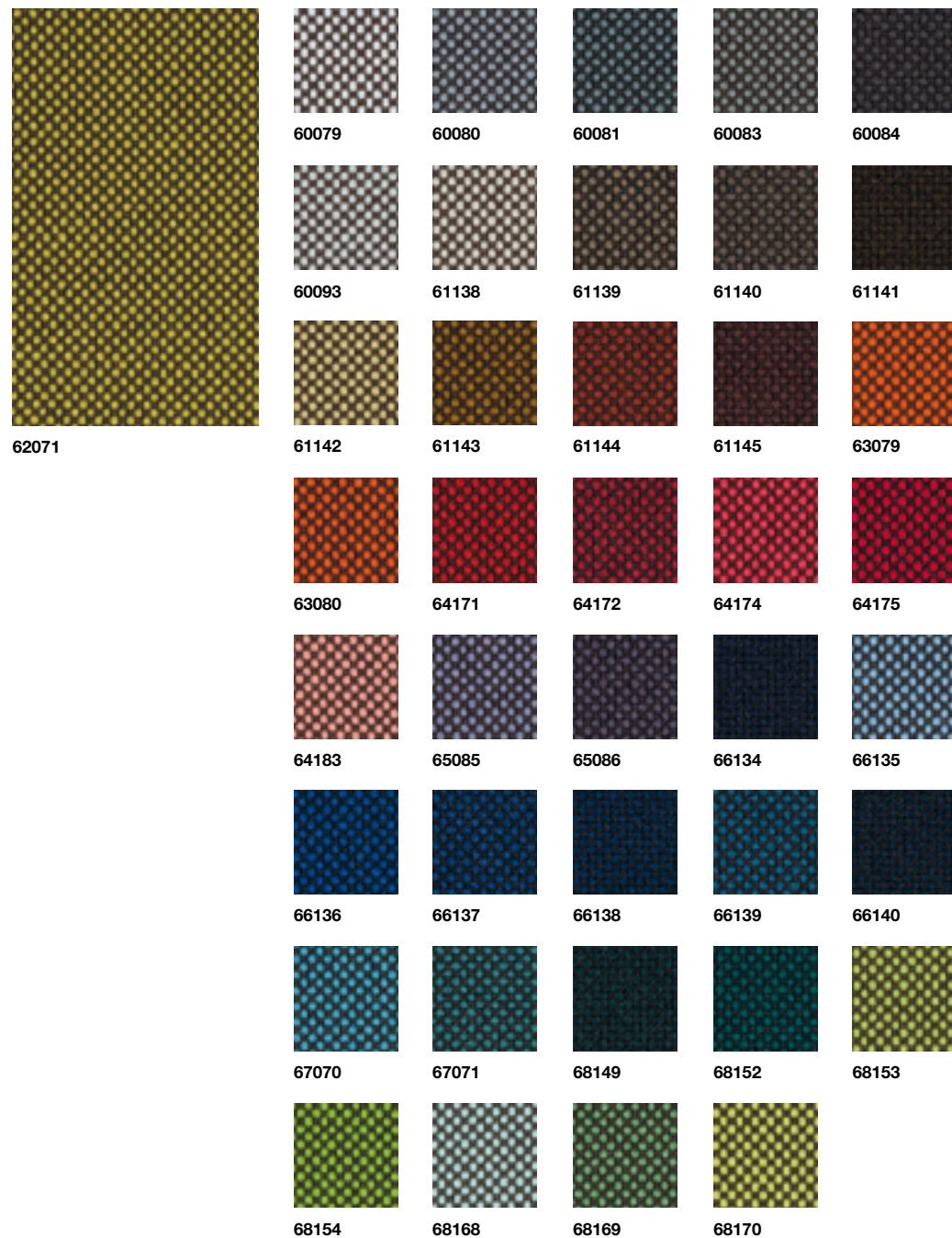

**Gabriel Textiles / Telas Gabriel**

Swing / Grade 6

Composition / Composición  
54%Wool-44%Post-consumer  
recycled polyester-2%polyamide  
54%Lana-44%poliéster reciclado-  
2%poliamida

Martindale test /  
Resistencia a la abrasión  
100.000 Cycles / Ciclos

Not suitable for loose cover.  
No válido para funda.



Capture / Grade 8

Composition / Composición  
85% Wool of New Zealand-15%  
Polyamide  
85% Lana de Nueva Zelanda-15%  
Poliamida

Martindale test /  
Resistencia a la abrasión  
200.000 Cycles / Ciclos

Suitable for loose cover.  
Válido para funda.



## In&out Textiles / Telas In&out

### Sand / Grade 1

Composition / Composición  
100% Dyed Acrylic Solution  
100% Acrílico teñido en masa

Martindale test /  
Resistencia a la abrasión  
17.000 Cycles / Ciclos

Not suitable for loose cover.  
No válido para funda.

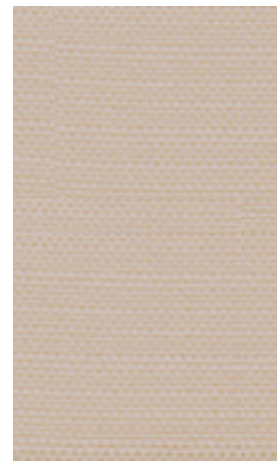

1181



1180



1883



1184

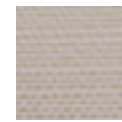

1882

### Silvertex / Grade 2

Composition / Composición  
Polyester Hi-loft2  
Poliéster Hi-loft2

Martindale test /  
Resistencia a la abrasión  
>100.000 Cycles / Ciclos

Not suitable for loose cover.  
No válido para funda.

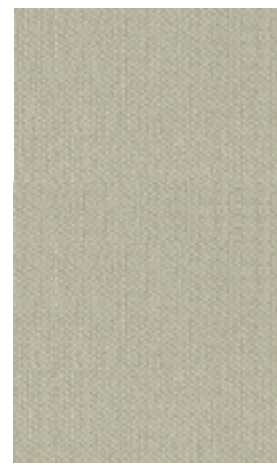

122-5009  
Sage



122-4004  
Ice

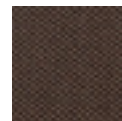

122-0005  
Mocca



122-4002  
Storm



122-1051  
Sisal



122-6061  
Mandarin



122-3001  
Turquoise



122-1078  
Champagne

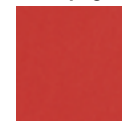

122-2012  
Sunkist

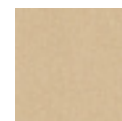

122-1010  
Beige



122-5019  
Celery



122-4024  
Meteor



122-0009  
Taupe

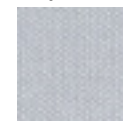

122-4001  
Plata

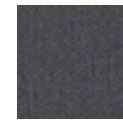

122-9002  
Carbon

## In&out Textiles / Telas In&out

### Solids & Stripes / Grade 2

Composition / Composición  
100% Sunbrella solution dyed  
acrylic  
Sunbrella acrílico teñido en masa

Martindale test /  
Resistencia a la abrasión  
20.000 Cycles / Ciclos

Not suitable for loose cover.  
No válido para funda.

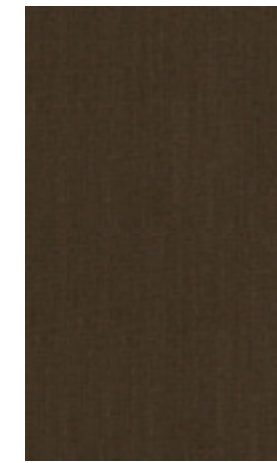

3127  
Mink brown

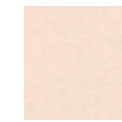

5453  
Canvas



3965  
Blush



3945  
Granny

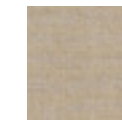

48009 00  
Arbor Pebble



3968 137  
Solids Peppers



3964  
Curacao

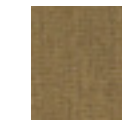

5476  
Heather beige

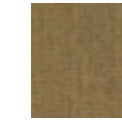

5476  
Heather beige



3941  
Adriatic

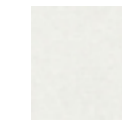

3741  
Silver Grey



3967  
Mint



3967  
Mint



3960  
Marble

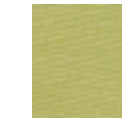

3970  
Lichen



5439  
Navy Blue

### Natte / Grade 3

Composition / Composición  
100% Sunbrella solution dyed  
acrylic  
Sunbrella acrílico teñido en masa

Martindale test /  
Resistencia a la abrasión  
25.000 Cycles / Ciclos

Not suitable for loose cover.  
No válido para funda.



10022  
Grey Chine

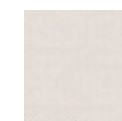

10020  
White

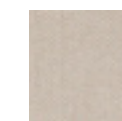

10021  
Canvas



10029  
Heather Grey

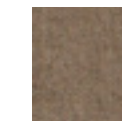

10064  
Carbon Sky

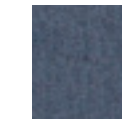

10064  
Carbon Sky



10028  
Heather Beige



10154  
Storm Chalk



10153  
Flanelle



10030  
Sooty



10030  
Sooty



## In&out Textiles / Telas In&out

### Chartres / Grade 6

Composition / Composición  
100% Sunbrella solution dyed  
acrylic  
Sunbrella acrílico teñido en masa

Martindale test /  
Resistencia a la abrasión  
250.000 Cycles / Ciclos

Not suitable for loose cover.  
No válido para funda.



CHA-J184140  
Rose



CHA-J193 140  
Pearl



CHA-J186 140  
Antique



CHA-J189 140  
Heather



CHA-J190 140  
Gold



CHA-J192 140  
Lichen



CHA-J181 140  
Bronze



CHA-J187 140  
Glacier



CHA-J185 140  
Mineral



CHA-J191 140  
Grey



CHA-J183 140  
Flanelle

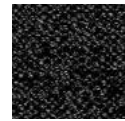

CHA-J182 140  
Sooty

### Lopi / Grade 8

Composition / Composición  
100% Sunbrella solution dyed  
acrylic  
Sunbrella acrílico teñido en masa

Martindale test /  
Resistencia a la abrasión  
50.000 Cycles / Ciclos

Not suitable for loose cover.  
No válido para funda.

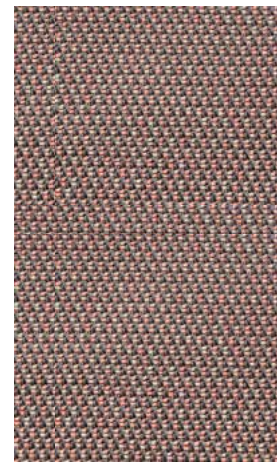

LOP R025 140  
Coral



LOP R033 140  
Snow



LOP R034 140  
Antique



LOP R019 140  
Sand



LOP R023 140  
Blush



LOP R033 140  
Snow



LOP R016 140  
Hemp

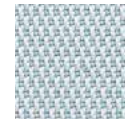

LOP R026 140  
Glacier

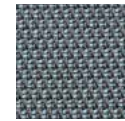

LOP R028 140  
Cloud



LOP R029 140  
Storm



LOP R035 140  
Plum

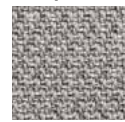

LOP R015 140  
Silver



LOP R017 140  
Charcoal

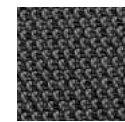

LOP R013 140  
Shadow

### Special thanks/Agradecimientos

**Zest Architecture**  
zestarchitecture.com

**Mas que espacio**  
masquespacio.com

**Sanahuja&Partners. Arquitectura**  
Hatgallery.com

**ConSORCI per a la Normalització Lingüística (CPNL)**  
http://www.cpnl.cat

**Viraje Arquitectura**  
www.viraje.es

**CRP Ciutat Vella**

**Vegamar**  
Vegamarseleccion.es

**Restaurante Malmö**  
www.restaurantemalmo.com

**Francisco Mangado**  
www.fmangado.es

**Fundació Pascual Maragall** (Barcelona)  
Architecture project / Proyecto de arquitectura:  
Juan Navarro Baldeweg

**Carmen Baselga\_Taller de proyectos**  
Photography / Fotografía: Héctor Rubio

**Edificio Emergencias 112** (Reus)  
Architecture project / Proyecto de arquitectura:  
ACXT Arquitectos

**Biblioteca Sant Josep** (Ontinyent)  
Architecture project / Proyecto de arquitectura:  
Ramón Esteve

**MUJI** (Barcelona)  
www.muji.es/shop

**Estudio Lavernia & Cienfuegos** (Valencia)  
Architecture project and interior design studio /  
Proyecto de arquitectura e interiorismo: Nacho  
Lavernia y Alberto Cienfuegos

**Academia 2Day Languages Valencias**  
www-2daylanguages.com

**Alfons Tost** (Accions Interiorisme)  
www.accionbcn.com  
Proyectos de interiorismo / Interior Design  
projects: Monvínic, Accions

**Bd ediciones** (Girona)

**Showroom EHD**

**Laura Alandes**  
Interior Design project / Proyecto de Interiorismo:  
Ma Khin Cafe

**Fran Silvestre Arquitectos**  
www.fransilvestrearquitectos.com

**Francesc Rifé**  
Proyectos de interiorismo / Interior Design  
projects: Indret Advocats, Iglesias Joiers,  
Residencia Primer Equipo Real Madrid,  
Caixa A-Diagonal Barcelona, Casa Olivella,  
Bodegas El Cep, Duravit, Restaurante Nuba,  
Apartamento EJ

**Biblioteca Montilivi** (Universitat de Girona)

**E/1:1 Mónica Tárrega Klein**  
www.escalaunouno.com  
Proyectos de interiorismo / Interior Design  
projects: Vivienda Escorial

**Auditorio Teulada-Moraira** (Alicante)  
Proyectos de arquitectura / Architecture  
project: Francisco Mangado

**Conselleria de Sanitat** (Valencia)  
Dirección General de Salud Pública

**Silvestre Navarro Arquitectos**  
Proyecto / Project: Casa para un carpintero  
www.silvestrenavarro.com

**Gunni&Trentino** (Barcelona)

**Office EG Neerpelt**  
Proyectos de interiorismo / Interior Design  
projects: Lens Ass Architecten  
www.lensass.be

**Espai Caixa Girona**

**Gallardo Llopis Arquitectos**  
www.gallardo-llopis.com

**Bodegas Ferrer Bobet. Priorat**  
www.ferrerbobet.com

**Banc Sabadell. Sant Cugat del Vallés**

**Hotel Aire de Bardenas**  
Tudena (Navarra)

**Making Cafe**  
Mercado de Colón (Valencia)

**Carlos Ferrater Arquitectura**  
www.ferrater.com

**Caro Hotel**  
www.carohotel.com

**Restaurante La Turqueta (Grupo Saona)**  
www.gruposona.com

**Autis Ingenieros**  
www.autis.es

### Designers/Diseñadores

Lievore Altherr Molina  
Jasper Morrison  
Patricia Urquiola  
Piergiorgio Cazzaniga  
Javier Mariscal  
Estudio Andreu

### Photography/Fotografía

Gerald Kiernan  
Estudio Andreu  
Eugeni Pons  
Elena Mahugo  
Salva López  
José Hevia Blach  
Robert Holden  
Enok Holsegard  
Xavier Molla  
Fernando Alda  
Bieke Claessens  
Jorg Brauer  
Fernando Guerra  
Sergio Guerra

### Graphic project/Proyecto gráfico

Antonio Solaz



✓ Addresses/Direcciones

---

**Andreu World**

Showroom Valencia (Spain)  
&Head Office Phone +34 96 180 57 00  
info@andreuworld.com

**Andreu World America**

Showroom Chicago (USA)  
&Head Office Phone 312 464 0900  
info@andreuworldamerica.com

**Andreu World Pacific**

Office Japan  
Phone +81 3 3549 5508  
info@andreuworldpacific.com

**Andreu World Karpatia**

Office Ukraine  
Phone +380.3131.54070  
info@andreuworldkarpatia.com

The paper used to produce this catalog comes from responsibly managed forests and other controlled sources for greater environmental protection.

El papel utilizado para producir este catálogo proviene de bosques gestionados de forma responsable y de otras fuentes controladas que garantizan la protección del medio ambiente.

Andreu World S.A.  
Copyright©AndreuWorld,  
01 / 2018

Printed in Spain

Esta publicación no puede ser reproducida en todo o en parte sin el permiso escrito del editor. Todos los modelos están protegidos mediante patente internacional.

This publication may not be reproduced in whole or in part in any manner whatsoever without the written permission of the publisher. All models are protected by international patent.